

***9516CW Installation
and
User Guide***



9516CW Important Tips

- *Wait for at least two rings to allow the phone to identify a caller and display the caller's name and/or number. You will have to subscribe to a Calling Line Identification service to take advantage of this feature.*
- *If the Handsfree mode (speakerphone) is not working, ensure that you have the Headset option disabled in the options list.*
- *The 9516CW is able to make and receive calls even during a power failure. Features such as the display, memory keys, and answering machine will not work without power.*
- *To call back local calls from the Callers List, be sure to remove the area code.*
- *Remember that there is a 30 minute limit for recording announcements and messages. Delete messages regularly to ensure that there is always room for incoming messages.*
- *To use the Call Waiting Identification feature, you must subscribe to a Call Waiting Identification service from your local telephone company.*
- *Some memory keys may be factory pre-programmed, and cannot be programmed by the user.*
- *Remember that there is a 24 digit limit on numbers and a 16 character limit on names stored in the Directory.*

Table of Contents

Introduction	1	Controlled playback using the Callers List	17
Key Descriptions	2	Playback Options	17
The Set Options list	3	Make Message New	17
Basic Installation	4	Selective message delete	17
Connecting the handset cord	4	Call screening	18
Connecting the line cord	4	Call intercept	18
Connecting an optional fax machine or modem	4	Calling party control	18
Connecting the power adaptor	4	Toll saver	18
Checking your telephone	5	Memos	19
Desk Mounting	5	Recording a memo	19
Optional Wall Mounting	5	Listening to a memo	19
Adjusting the Display	5	Deleting a memo	19
The Set Options Key	5	Directory	20
Basic Features	6	Creating a New Directory Entry	21
Making a call	6	Entering Names	22
Answering a call	6	Call Announce (Voice Tag)	22
Putting a call on hold	6	Call Announcement (Voice Tag) options	23
Making a Handsfree call	7	Saving a displayed number to the Directory	25
Putting a call on mute	7	Saving a memory key entry to the Directory	26
Using the Redial List	7	Personalized Greetings for Directory entries	26
Call Waiting Identification	8	Finding items in the Directory	27
Super Call Waiting Identification	8	Making a call from the Directory	28
SuperFlash	9	Editing in the Directory	28
Turning the display of Call Waiting Identification on or off	10	Deleting items from the Directory	29
Changing the display language	10	Mailboxes	29
Setting the date and time	10	Mailbox Greetings	30
Turning the ringer on or off	11	Assigning people to a Mailbox	32
Setting the ring tone and ringer volume	11	Callers List	33
Controlling the ringer volume	11	Using the Callers List	33
Controlling the handset volume	11	Setting up the Callers List	33
Controlling the speaker volume	11	Finding items in the Callers List:	33
Turning the Answering Machine on or off	12	Making a call from the Callers List	34
Number of Rings before answering	12	Editing in the Callers List	34
Greetings	13	Listening to messages in the Callers List	34
The General Greeting	14	Saving displayed numbers from the Callers List	35
The Special Greeting	14	Deleting items from the Callers List	35
The Private Greeting	15	Memory keys	36
Recording Greetings	15	Saving numbers and names to memory keys	36
Messages	16		
Knowing when you have a message	16		
Audible Message Alert	16		
Auto playback	16		

Table of Contents

Saving from the display to memory keys	37	General display messages	58
Recording a Call Announcement (Voice Tag) for a memory key	38	Callers List display messages	59
Labeling the memory keys	38	Learning about the Lights	60
Personalized Greetings for Memory keys	38	Set indicator light messages	60
Making calls from memory keys	39	Handsfree indicator light messages	60
Editing memory keys	40	Viewing multiple display and light messages	60
Deleting memory keys	40	Special Information	61
Saving features in memory keys	41	Troubleshooting	62
Using feature keys	41	Index	
Saving a feature and light to memory keys	42	Warranty returns and repairs	
Using Feature Light keys	42		
Advanced Features	43		
Adding a timer key	43		
Using the call Timer	43		
Deleting a timer key	43		
Adding a page key	43		
Using the page	44		
Deleting a page key	44		
Installing the page lines	45		
Selecting the dial pad mode	45		
Entering area codes	46		
Entering Dialing Restrictions	47		
The Security Numbers feature	48		
The Fax Switch	49		
Incoming Calls	49		
Outgoing Calls	49		
Setting the Fax Switch	49		
Copying the Directory to another 9516CW telephone	50		
Call Blocking	51		
Using a headset	51		
Changing the headset mode	51		
Automated Attendant	52		
Example of Automated Attendant	52		
Remote Notification	54		
Remote Access	55		
Remote Access	56		
Display messages and lights	57		
The Callers List screen	57		
Knowing when you have a Voice Mail message	57		
Clear Message Waiting	57		

Introduction

Thank you for purchasing Aastra's 9516CW telephone. We think you'll find it's full of exciting features. With a built-in digital answering machine, personal Directory, and a Callers list, your new telephone is designed to take full advantage of the latest services offered by your local telephone company.

When you subscribe to services such as Calling Line Identification and Call Waiting Identification[†] through your local telephone company, your 9516CW will show you all the caller information you'll need on its three-line back-lit display. For example, before you even answer a call you'll know who is calling, even if it's a Call Waiting call. And Call Waiting identification information can appear on two telephone extensions at the same time so that someone at either extension can initiate the switch to a Call Waiting call. Your telephone will also tell you how many messages and new callers you have.

The answering machine doesn't need an audio tape or batteries to work, so it's easy to set up. All you have to do is plug in your telephone and it's ready to receive messages. It's also very reliable. You will not lose any of your messages or greetings (outgoing messages) if there is a power failure of up to 72 hours.

You can set up a personal Directory in which you can enter up to 75 names and numbers. And for each of these numbers, you can record personalized greetings and Call Announcements (Voice Tags).

Your Callers List will log up to 75 incoming calls and messages, and you can now record personalized greetings and Call Announcements (Voice Tags) to numbers stored in memory keys.

The Options List makes it easy for you to personalize your telephone, and the back-lit three-line display provides walk-through prompting that makes all of the many features and options even easier to customize. Please read on for more information on the many features of your 9516CW.

[†]The names of these services may vary from area to area.

Key Descriptions

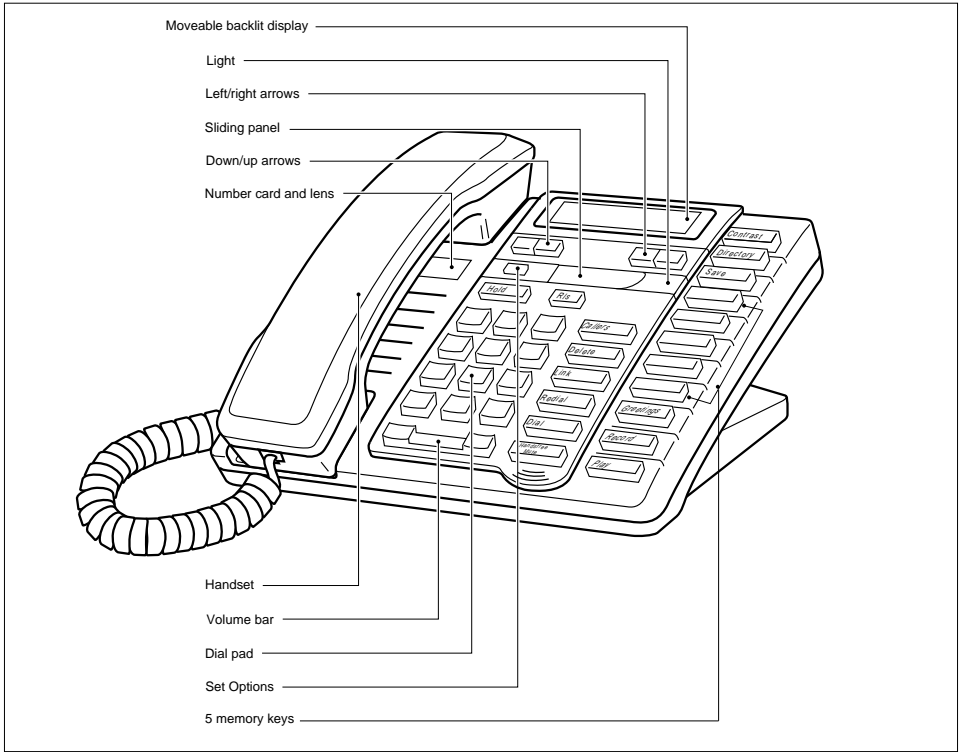

Contrast

Cycles through eight settings to adjust the display contrast.

Directory

Allows you to store 75 numbers and names. You can also assign mailboxes and record customized messages and Call Announcements (Voice Tags).

Save

Stores numbers and names in the Directory and in memory keys. This key also saves recordings, greetings and memos.

↓ ↑

Allows you to move up and down any list such as the Set Options, Directory, Callers List, or Redial List.

←

Allows you to backspace and erase. This key is useful when predialing and when adding or changing numbers and names in the Directory, Callers List or in memory keys.

→

Adds a space when entering names in the Directory or in memory keys. Allows you to view several messages on the display.

Hold

Puts the call on hold, inserts a pause, shifts between upper and lower case or pauses during the playback of a message.

RLS

The Release key always hangs up a call. Also allows you to leave any list such as the Set Options List, Callers List, Redial List or Directory.

Callers

Allows you to access a list of people who called as well as any messages they have left.

Delete

Allows you to erase memory keys, delete single or all items in the Directory and Callers List as well as the entire Redial List. You can also delete greetings and messages.

Link

When you hear the Call Waiting tone or to initiate Three Way Calling, press Link to activate these features. Link is also known as Flash.

Redial

Allows you access to a list of the last ten numbers you dialed.

Dial

Dials any displayed number. Activates Handsfree mode if you have not lifted the handset.

Handsfree Mode

Activates the Handsfree speaker and microphone so you can listen and talk to a caller without lifting the handset. Also allows you to mute a handsfree call so that a caller cannot hear you.

◀ ▶

Allows you to adjust the receiver, speaker, and ringer volume.

Memory keys store numbers, names, and features. You can also assign mailboxes and record customized messages and call announcements (voice tags).

Greetings

Allows you to review your mailbox greetings (outgoing messages).

Record

Allows you to record your greetings and memos.

Play

Allows you to listen to your messages, memos or greetings.

□

The unlabeled Set Options key is hidden under the sliding panel and allows you to access 26 options to customize your telephone.

The Set Options list

Set Options list	page
01. Change display language	10
02. Set the time and date	10
03. Select the ring tone	11
04. Add a Timer key	43
05. Select the dial pad mode	45
06. Clear Message Waiting	57
07. Enter area codes	46
08. Change the Callers List	33
09. Answering Machine on or off	12
10. Toll Saver	18
11. Number of Rings	12
12. Set Password	55
13. Screen Calls	18

Set Options list	page
14. Audible Message Alert	16
15. Call Announce (Voice Tag)	22
16. Call Blocking	51
17. Remote Notification	54
18. Set Remote Number	54
19. Auto Attendant	52
20. Change the Fax Switch	49
21. Add a Page key	43
22. Headset	51
23. Enter Dialing Restrictions	47
24. Data transfer	50
25. Security Feature	48
26. Call Waiting ID display on or off	10

Note : Please refer to each section for the default settings for the above options.

Basic Installation

This section explains how to install the device.

Connecting the hardware



Checking your telephone

When you first plug in your 9516CW, the telephone initializes itself and then you may see a message asking you to make a language selection. Follow the directions on the display to select a language.

Your telephone also runs a test to ensure that the line cord is connected properly. If the test fails, the display prompts you to check the line cord. Make sure that all connections are fastened securely.

Desk Mounting

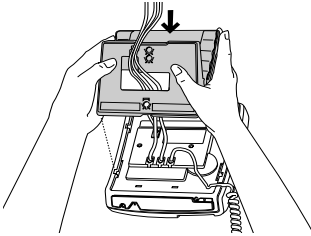

Lower the stand into the slots on the base of the telephone, as shown above.

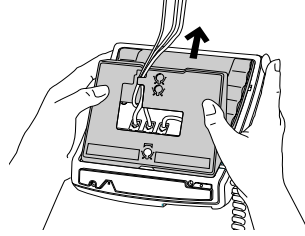

Slide the stand back until it clicks into the locked position.

Optional Wall Mounting †

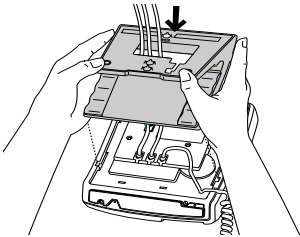

Lower the stand into the slots on the base of the telephone, as shown above.

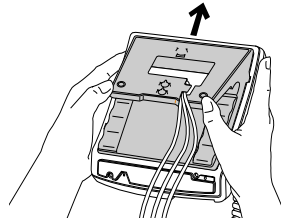

Slide the stand back until it clicks into the locked position.

Adjusting the Display

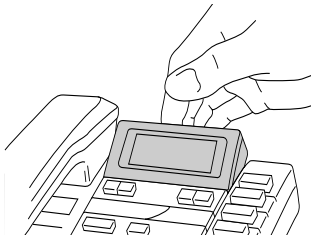

Place your 9516CW on a table or hang it on a wall, then adjust the display.

The Set Options Key



Move the sliding panel over to the right to reveal the Set Options key.

†We recommend that you use a wall mounting plate which is available through your telephone company. If you are going to wall mount your 9516CW, use the 20 cm (8") line cord supplied with your telephone.

Note: The Ringer Equivalence Number (REN) is 1.4B for the 9516CW telephone. Please see the base of your telephone or the Regulations sheet for more regulatory and safety information.

Basic Features

Making a call

You can use the 9516CW to simply make a regular call, or else you can predial a telephone number to ensure it is correct before it is dialed out. Follow the procedures below to make a regular or predialed call.

To make a regular call:

1. Lift the handset or press .
2. Enter the number using the dial pad.

To make a predialed call:

1. Enter the number using the dial pad.
2. Lift the handset or press either OR .

Note : If you have turned on the live dial pad option, you will not have to lift the handset or press any buttons after entering the number. Refer to **Selecting the dial pad mode** on page 45.

Answering a call

To answer a call:

1. Lift the handset or press .

Calling Line Identification information is sent from the telephone company to your 9516CW telephone between the first and second ring (if you subscribe to the Calling Line Identification service through your local telephone company). Therefore, if you want the telephone number of the incoming call to appear on the display and in the Callers List, you must wait until the information appears on the display before answering the telephone.

Note : Contact your local telephone company to subscribe to CLID services.

Putting a call on hold

When you put a call on hold it is important to hang up the handset.

To put a call on hold and take a call off hold:

1. Make or answer a call.
2. Press . The display shows that the call is on hold.
3. Hang up the handset.
4. To retrieve the call, lift the handset or press either or . If you don't retrieve the call within 15 minutes, the call is automatically dropped.

Note : The 9516CW automatically releases the held call when a person on an extension telephone picks up the call. If you don't hang up the handset after you have put a call on hold and that call is picked up by someone at another extension, the call is taken off hold but remains connected to your telephone. If this happens, any background noise from your area will be heard by the caller and the person at the other extension.

Making a Handsfree call

You don't have to use the handset to use your telephone. Instead, you can use Handsfree mode to place a call, or you can switch to Handsfree mode while a call is already in progress.

To dial without picking up the handset:

1. Press .
2. Enter the number using the dial pad.

To switch to a Handsfree call:

1. Lift the handset.
2. Enter the number using the dial pad.
3. When the call is answered, press .
4. Hang up the handset.

Putting a call on mute

You can turn off the microphone so that the caller cannot hear you but you can still hear the caller. Muting a call only works when you are in Handsfree mode.

To mute a call:

1. Press .
2. Without lifting the handset, make a call.
3. To turn the microphone off, press again. You can hear your caller but your caller cannot hear you. The light beside flashes.
4. To speak to your caller, press again. Each time you press , you turn the microphone on or off.
5. When the call is over, press .

Using the Redial List

The Redial List stores the last ten numbers you dialed. When you press the last number you called appears on the screen. You can scroll through the list to view the other numbers. Note that if you press after either lifting the handset or pressing , your telephone automatically dials the last number in the Redial list.

To make a call from the Redial List:

1. Press . The display shows the last number you dialed.
2. Find the number you wish to call by pressing .
3. When the number is displayed, lift the handset or press either or .

There may be times when you want to delete the contents of the Redial List. For example, if you have dialed a personal number such as a password or your calling card number, you may not want it to appear in the list where anyone can see it.

To delete the Redial List:

1. Press .
2. Press twice. The entire Redial List is deleted.

on †

displaying Call Waiting Identification information of a second
re a call in progress. When you are on a call and you hear the
Waiting information is displayed as shown below.

Information
displayed.

When you hear the Call Waiting tone,
Caller Two's information is displayed.

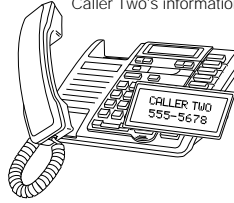

Speak to the new caller, simply press **Link** . Your first
party switch between callers as often as you like by
 and see a caller's Identification information
the caller has hung up. Your Call Waiting
party are not answered. For more information
3.

Identification option must be enabled
information on the display. Refer
on or off on page

Information †
Identification feature
Information compatible
the same time

Information
displayed

SuperFlash †

The SuperFlash feature allows either of two telephone extensions to activate the link to a Call Waiting call. When a person at either extension presses **Link** both extensions switch to and speak with the Call Waiting caller as shown in the diagrams below.

Incoming caller's information (Caller One) is displayed.

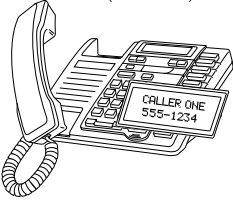

Extension telephone picks up and also speaks with Caller One.

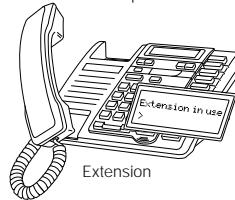

Call Waiting tone sounds and Caller Two's information is displayed on both extensions.

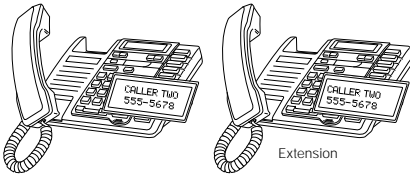

Either telephone can press **Link** to speak with Caller Two.



Both telephones speak to Caller Two and see the displayed information.

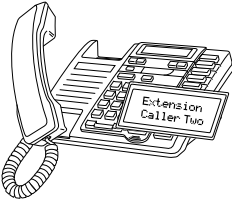

Either telephone can press **Link** again to switch back to Caller One.



Calls will not be disconnected when you press **Link**. If you wish to return to your first caller press **Link** again. The 9516CW and one other Aastra SuperFlash-compatible telephone extension will switch between the two callers each time you press **Link**. Once you have switched to one caller by pressing **Link**, you must wait three seconds before you can switch back to the previous caller. When you press **Link** and see a caller's Identification information but only hear a dial tone, it means that the caller has hung up. To end a call, ensure you can see that call's identification information (you may have to press **Link**), then press **Fls**.

Note: SuperFlash and Super Call Waiting Identification only work with Aastra SuperFlash and Super Call Waiting Identification-compatible telephones.

† You must subscribe to your telephone company for the Call Waiting with Calling Line Identification service.

Turning the display of Call Waiting Identification on or off

You can choose whether or not Call Waiting Identification is displayed on your telephone.

To turn the display of Call Waiting Identification on or off:

1. Press the Set Options key.
2. Use \downarrow \uparrow to scroll to number 26 or press $\boxed{26}$ to go directly to the item.
3. Press \otimes to turn the Call Waiting Identification display on or off.
4. Press \boxed{Rls} .

Note : Turning the display of Call Waiting Identification on or off does not turn the feature itself on or off. When the Call Waiting display is turned off, you will still hear the Call Waiting tone when a Call Waiting call comes in, but the Identification for the Call Waiting caller will not appear on your screen. Contact your local telephone company to subscribe or unsubscribe to Calling Line Identification with Call Waiting Identification services.

Changing the display language

You may wish to change the language of the display messages and prompts.

To change the language:

1. Press the Set Options key.
2. Use \downarrow \uparrow to scroll to number 1 or press $\boxed{01}$ to go directly to the item.
3. Press \otimes to select the language.
4. Press \boxed{Rls} .

Setting the date and time

If you subscribe to the Calling Line Identification service from your telephone company, the date and time are set automatically after you receive your first incoming call. If you do not subscribe, you must set the date and time manually.



To set the date and time manually:

1. Press the Set Options key.
2. Use \downarrow \uparrow to scroll to number 2 or press $\boxed{02}$ to go directly to the item.
3. Follow the instructions on the display.
4. Press \boxed{Rls} .



To resume the automatic date and time setting (if the date and time has been set manually), disconnect the power supply, then re-connect it. After your first incoming call, the date and time are automatically set.

Turning the ringer on or off

To turn the ringer on:

1. Press the right side of  . Continue pressing the right hand side until you reach the desired ring volume.

To turn the ringer off:









1. Press the left side of  . Continue pressing the left hand side until the ringer is off. **Ringer is OFF** appears on the display.

Note: Do not lift the handset while you are turning the ringer on or off.



Setting the ring tone and ringer volume

You can choose one of four different ring tones and set the ringer volume.



To set the ring tone and volume:

1. Make sure that the ringer is turned on.
2. Press the Set Options key.
3. Use   to scroll to number 3 or press   to go directly to the item.
4. Follow the instructions on the display.
When choosing the ring tone, press   to adjust the volume.
5. Press  to end when you are satisfied with the ring tone and ringer volume.
Note : You cannot turn the volume off when you are choosing the ring tone.
6. Press .



Controlling the ringer volume

When the telephone is idle or ringing, you can press the left or right side of the volume bar   to adjust the ringer volume.

Controlling the handset volume

When you are on the telephone, you can press the left or right side of the volume bar   to adjust the handset volume. When you have completed your call, the handset volume returns to default.

Controlling the speaker volume

When you are listening using handsfree, you can press the left or right side of the volume bar   to adjust the speaker volume. Call Announcements (Voice Tags) will be played at the speaker volume.

Turning the Answering Machine on or off

You can turn the answering machine on or off through the Set Options list. The default setting is on.

To turn the answering machine on or off:

1. Press the Set Options key.
2. Use to scroll to number 9 or press to go directly to the item.
3. Press to turn the answering machine on or off.
4. Press .

Even when the answering machine is turned off it will answer the call after 15 rings. This allows you to turn on the answering machine using the Remote Access feature. For information about Remote Access, see **Remote Access** on page 55.

Number of Rings before answering

You can set the number of rings the answering machine waits before answering. You can choose from two to nine rings. The default setting is four rings.

To set the number of rings:

1. Press the Set Options key.
2. Use to scroll to number 11 or press to go directly to the item.
3. Press to set the number of rings.
4. Enter the number of rings using the dial pad.
5. Press .
6. Press .

Greetings

When the answering machine is turned on, a greeting is played to your incoming callers when you are unavailable to take their calls. The 9516CW greets your callers with a factory-recorded General Greeting that asks your callers to leave a message. If you choose not to use the factory General Greeting, you can record your own. See **The General Greeting** on page 14 for more information.

The Special Greeting is the same as the General Greeting except that it is activated by a distinctive ring. See **The Special Greeting** on page 14 for more information.

When you have the Call Blocking option turned on, your 9516CW intercepts calls from people who have blocked their telephone numbers and plays the Private Greeting. See **The Private Greeting** on page 15 and **Call Blocking** on page 51 for more information.

Personal greetings are played when you want a specific greeting played to people that you have entered in your Directory or memory keys. See **Directory** on page 20, **Personalized Greetings for Directory entries** on page 26, and **Personalized Greetings for Memory keys** on page 38 for more information.

You can also assign Mailbox greetings to selected groups of people that have been entered into your Directory. See **Mailbox Greetings** on page 30 and **Directory** on page 20 for more information.

To achieve the best sound quality for recorded greetings and Call Announcements, it is recommended that you record by speaking into the handset instead of the handsfree microphone.

Sometimes callers choose not to listen to your greeting before recording a message. They can press **#** to skip your greeting and leave a message immediately. Note, however, that pressing **#** will not allow callers to skip the Automated Attendant greeting.

Note: The Special, Private, and Personalized Greeting features require that you subscribe to your telephone company for the Calling Line Identification service.

The General Greeting

If you choose not to use the factory-recorded General Greeting, you can record your own. The purpose of the General Greeting is to greet your callers and provide them with information about leaving messages. After you finish recording, you should replay your greeting to ensure it sounds the way you intended.

For example:

“Hi. This is Mike Prentice. I’m unable to take your call right now. Please leave a message after the tone and I will return your call as soon as possible.”

While you are recording your greeting, you can press to pause. A pause is useful if you are interrupted while you are recording your greeting. When you are ready to continue recording your greeting, press again. The pause is not included in your greeting and will not be heard by the callers.

Note : Although you can use either Handsfree or the handset to record your greeting, a better recording results when you speak directly into the handset.

The Special Greeting

The Special Greeting is activated by a Distinctive Ring. For your telephone to receive a Distinctive Ring, you must subscribe to your telephone company for Distinctive Ringing[†]. The telephone company will then provide you with an additional telephone number that has a slightly different ring. The 9516CW will use the two ring types to determine whether the caller should hear the General Greeting or the Special Greeting.

For example, the Special Greeting could be very useful if you are operating a business out of your home. You could record a residential message for the General Greeting, and then record a business message for the Special Greeting, as follows:

General Greeting - *“Hi you’ve reached the Anderson’s. We’re unable to take your call right now. Please leave your name and number and we’ll give you a call back as soon as we can.”*

Special Greeting - *“Thank you for calling Anderson Graphics. No one is available to take your call right now. Please leave your name and number and someone will get back to you as soon as possible.”*

All you would have to do in this case is give your business customers and associates your Distinctive Ringing number, and they would only hear the business message (the Special Greeting). On the other hand, friends and family who have your regular home number would only hear the residential message (the General Greeting).

You can also have a caller who doesn’t have the Distinctive Ring number hear the Special Greeting by assigning it to that caller’s number in the Directory or a memory key.

Note : If you subscribe to Long Distance Ringing, then the Special Greeting will be played when you receive a long distance call. Also, you cannot use the Special Greeting and the Fax Switch feature at the same time.

[†] The actual name for the Distinctive Ringing service varies from area to area. This service may also be known as *Ident-a-call, Ident-a-ring, Teen Service, Signal Ring, Custom Ringing* or *Long Distance Ringing*.

The Private Greeting †

The Private Greeting is played to callers who have blocked the display of their telephone numbers. Calling Line Identification for these callers appears as “Private name” and/or “Private number”.

You must record the Private Greeting before it can be played to callers who have blocked their telephone numbers or names. If you do not record a Private Greeting, these callers will hear the General Greeting.

For example:

“You are calling from a private number, please identify the number you are calling from and I will return the call.”

The Private Greeting is commonly used in conjunction with the Call Blocking feature. For more information about the Call Blocking feature, see **Call Blocking** on page 51.

Recording Greetings

To record your greeting:

1. Press **Greetings**.
2. Press **↓** **↑** to find the type of greeting you want to record.
3. Press **Record**.
4. Lift the handset and press **Record** again.
5. Record your greeting.
6. Press **Save** to end your recording.
7. Press **RLS**.

To listen to your greeting:

1. Press **Greetings**.
2. Press **↓** **↑** to find your greeting.
3. Press **Play**.
4. Press **RLS**.

To change your greeting:

1. Press **Greetings**.
2. Press **↓** **↑** to find the greeting you want to change.
3. Press **Record**.
4. Lift the handset and press **Record** again.
5. Re-record your greeting.
6. Press **Save** to end your recording.
7. Press **RLS**.

† You must subscribe to your telephone company for the Calling Line Identification service.

To delete your greeting:

1. Press **[Greetings]**.
2. Press **[↓]** **[↑]** to find the greeting you want to delete.
3. Press **[]** twice.
4. Press **[Rls.]**.

Messages

The maximum recording time for each greeting and incoming message is two minutes. The maximum total time for all of your greetings and messages is 30 minutes. As you delete messages and delete or record memos, the amount of time remaining is shown on the display.

Knowing when you have a message

The 9516CW indicator light flashes slowly to let you know when you have a message and **× New Messages** appears on the display.

Audible Message Alert

You can also program the 9516CW to alert you audibly when there is a message or a memo for you. A reminder tone sounds every 20 seconds reminding you that you have a message or memo.

To enable audible message alert:

1. Press the Set Options key.
2. Use **[↓]** **[↑]** to scroll to number 14 or press **[14]** to go directly to the item.
3. Press **[*]** to enable or disable audible message alert.
4. Press **[Rls.]**.

Auto playback

You can listen to all of your new messages in the order that they were left through the handsfree speaker.

To listen to your messages:

1. Press **[Play]**.
2. Press **[*]** for the General mailbox, **[#]** for the Special mailbox, or one of the dial pad numbers to select the mailbox.
Note : This selects all of the messages from a single mailbox. If you want to listen to all of the messages in all of the mailboxes, do not select a mailbox.
3. Press **[Play]**. Your messages will be played through the Handsfree speaker.
Note : If you want to hear your messages privately, lift the handset before pressing **[Play]** the second time.

Controlled playback using the Callers List

You can select or screen the messages that are played back by using the Callers List.

To select the order of messages:

1. Press .
2. Press to find the message you want.
3. Press to listen to a message.
4. After you have listened to your message, press .

Playback Options

There are five options you can use when you are listening to your messages:

- pressing once allows you to listen to your messages at a faster than normal speed and still understand the message,
- pressing once skips back five seconds in the message and returns to normal speed,
- pressing once pauses the message,
- pressing advances to the next message,
- pressing twice erases the message during controlled playback only (i.e., when you select a message from the callers list).

Make Message New

You might have listened to a message that was intended for someone else. The 9516CW allows you to make the message new again.

To make a message new:

1. Press .
2. Use to find the message that you want to make new.
3. Press . The indicator light begins flashing.
4. Press .

Selective message delete

You can delete individual messages at any time without changing the order of the message list.

To delete messages one at a time:

1. Press .
2. Use to find the message you want to delete.
3. Press twice.
4. Press .
5. To continue deleting messages one at a time, repeat steps 1 through 4.

To delete all messages:

Note : When you delete all messages, you also delete all entries in the Callers List.

1. Press **[Callers]**.
2. Press **[↓]** once.
3. Press **[Delete]** twice.
4. Press **[Rls.]**.

Call screening

When the 9516CW answers a call, your greeting and the voice of the person calling is played back through the handsfree speaker. You can choose to pick up the call or let the call go to the answering machine. The Call Screening option is on by default.

To disable call screening:

1. Press the Set Options key.
2. Use **[↓]** **[↑]** to scroll to number 13 or press **[1]****[3]** to go directly to the item.
3. Press **[*]** to enable or disable call screening.
4. Press **[Rls.]**.

Call intercept

If the 9516CW answers a call and you want to speak to the caller, you can disconnect the recording by either lifting the handset, pressing **[Handsfree Mute]** or by picking up the handset from an another extension telephone.

Calling party control

If your caller decides not to leave a message and hangs up, the 9516CW stops recording and hangs up. The call will still be logged in the Callers List.

Toll saver

When you have the Toll Saver option enabled and you call the 9516CW, the number of rings prior to answering tells you if there are any new messages. If the answering machine answers on the second ring, there has been a new message recorded. If there have been no new messages recorded, the 9516CW answers after the number of rings you have specified in the options list. This is particularly useful if you are calling long distance or from a pay phone. The Toll Saver option is disabled by default.

Note : You must set the 9516CW to answer after three or more rings in order for the Toll saver feature to work.

To enable the toll saver:

1. Press the Set Options key.
2. Use **[↓]** **[↑]** to scroll to number 10 or press **[1]****[0]** to go directly to the item.
3. Press **[*]** to enable the toll saver.
4. Press **[Rls.]**.

Memos

If you are going out and want to leave a message for someone, you can record a memo directly into the 9516CW. Memos can be retrieved at the telephone or remotely.

Memos are stored in the Callers List along with your messages. The set indicator light flashes letting you know there is a memo. If it is a new memo, the display shows: **× New messages.**

For example, if you wanted to remind Gino of his dentist appointment, you would record:

“Remember Gino, you have a dentist appointment at 2:30 p.m. today.”

Recording a memo

To record a memo:

1. Press **[Record]**.
2. Lift the handset and press **[Record]**.
3. Record your memo.
4. Press **[Save]**.
5. Press **[Play]** to review your memo or **[Save]** to move on.
6. Select the mailbox you want your memo stored in.
Note : If you do not select a mailbox, the memo is stored in the General Mailbox.
7. Press **[Save]**.
8. Press **[Rls]**.

Listening to a memo

To listen to a memo:

1. Press **[Callers]**.
2. Press **[↓]** **[↑]** to find the memo.
3. Press **[Play]**.
4. Press **[Rls]**.

Deleting a memo

To delete a memo:

1. Press **[Callers]**.
2. Press **[↓]** **[↑]** to find the memo you want to delete.
3. Press **[Delete]** twice.
4. Press **[Rls]**.

Note : The 9516CW also allows you to make memos new. See **Make Message New** on page 17.

Directory

The 9516CW stores the numbers and names of up to 75 of your business associates, clients, contacts, and friends in your Directory. You can dial these numbers by selecting them.

Names are sorted alphabetically starting with their first character. (If you want your Directory sorted by the last name, enter the last name first.) If you do not enter a name, the item is sorted by telephone number. The Directory items with only a telephone number are numerically sorted at the beginning of the Directory.

You also use the Directory to assign Personalized Greetings, Mailbox Greetings and Call Announcements (Voice Tags) to phone numbers.

A greeting is the message that callers hear when they are leaving a message on the 9516CW. These greetings can be personalized for a particular person or group of people stored in your Directory. (For more information on greetings in general, see **Greetings** on page 13.)

A mailbox is a storage place for messages. The 9516CW has 12 mailboxes. When someone calls and their number matches a Directory item, the call is automatically routed to the mailbox assigned to it in the Directory. (For more information about mailboxes, see **Mailboxes** on page 29 and **Mailbox Greetings** on page 30.)

A Call Announcement (Voice Tag) can be recorded for each person that you have entered into your Directory. This announcement is played through the handsfree speaker of the 9516CW when someone at that number calls so you know who is calling without looking at the telephone display. (For more information about Call Announce (Voice Tag), see **Call Announce (Voice Tag)** on page 22).

Note : To achieve the best sound quality for recorded greetings and Call Announcements, it is recommended that you record by speaking into the handset instead of the handsfree microphone.

Creating a New Directory Entry

To save a new entry to the Directory:

1. Press .

2. Press .

3. Enter the number (up to 24 digits) using the dial pad.

4. Press . Only the number is stored at this point.

5. If you do not want a name, go to step 6. To enter a name, use the dial pad. See **Entering Names** below.

6. Press .

7. Select the mailbox number you want to assign to this person. If you do not select a mailbox, the General Mailbox is assigned. See **Mailboxes** on page 29.

8. Press .

9. Lift the handset and press to record a Call Announcement (Voice Tag). See **Call Announce (Voice Tag)** on page 22.
Note : If you do not want to record a Call Announce message, go to step 13.

10. Record your Call Announcement (Voice Tag) after the tone.

11. Press .

12. Press to review your recording.

13. Press to end your recording.

14. Press to record a personalized greeting.

15. Pick up the handset and press .

16. Record your personalized greeting after the tone.

17. Press .

18. Press to review your recording.

19. Press .

Entering Names

You can enter names (up to 16 letters) to correspond with numbers you have entered into the Directory or a memory key. The following paragraphs explain how to enter letters using the dial pad. Before you can use the dial pad to enter names, you must first save or edit a number in the Directory or a memory key.

To program a name, find the dial pad key that has the first character of the name. Keep watching the display as you press the key until that character appears on the display. Press a different dial pad key for the next character. If the next character is on the same key, press → to move to the next space. To display upper case letters, press Hold , then press the appropriate dial pad key.

For example: to enter the name **Ruth**, press these keys:

7 7 7, 8 8, →, 8, 4 4

If you wish to change a digit or letter after you have entered it, press ← to erase it.

1 , - ' & . () 1

2 a A b B c C 2

3 d D e E f F 3

4 g G h H i I 4

5 j J k K l L 5

6 m M n N o O 6

7 p P q Q r R s S 7

8 t T u U v V 8

9 w W x X y Y z Z 9

* *

0 0

#

To backspace and erase a mistake, press ← . To insert a space, press → .

Call Announce (Voice Tag)

You can record a brief announcement associated with an entry in the Directory. See **Creating a New Directory Entry** on page 21 for more information on Directory entries. Generally this announcement is the name of a person matching the entry. When an incoming number matches a number in the Directory, the Call Announcement (Voice Tag) is played through the 9516CW speaker.[†]

To record a name for Call Announce (Voice Tag) to the Directory:

1. Press Directory .
2. Press ↓ ↑ to scroll to the name or use the dial pad to enter the name. For information about entering names, refer to **Entering Names**, above.
3. Press ← to begin editing.
4. Press Save three times.
5. Lift the handset and press Record .
6. Record the announcement.
7. Press Save twice.
8. Press Rls.

Note : If you have adjusted your speaker volume, your Call Announcement (Voice Tag) will be played through the speaker at the new volume. See **Controlling the Speaker Volume** on page 11 for more information.

[†] You must subscribe to your telephone company for the Calling Line Identification service.

You can also record a Call Announcement (Voice Tag) to a programmed memory key.

To record a Call Announcement (Voice Tag) to a programmed memory key:

1. Press the desired memory key.
2. Press .
3. Press three times.
4. Lift the handset and press .
5. Record the announcement.
6. Press twice.
7. Press .

Note: The Live dial pad option must be turned off to edit memory keys. If you have adjusted your speaker volume, your Call Announcement (Voice Tag) will be played through the speaker at the new volume. See **Controlling the Speaker Volume** on page 11 for more information.

Call Announcement (Voice Tag) options

There are three different choices under the Call Announcement (Voice Tag) option.

No Announce :

When you choose No Announce, nothing is played through the 9516CW speaker after the first ring. No Announce is enabled by default.

To enable No Announce:

1. Press the Set Options key.
2. Use to scroll to number 15 or press to go directly to the item.
3. Press to change.
4. Press for No Announce.
5. Press .

Name Only:

When you choose Name Only, the 9516CW announces the name through the handsfree speaker if you have recorded a Call Announcement (Voice Tag) for that number in your Directory.

To enable Name Only:

1. Press the Set Options key.
2. Use to scroll to number 15 or press to go directly to the item.
3. Press to change.
4. Press once to go to Name Only.
5. Press for Name Only.
6. Press .

For example: If someone in your Directory named Linda calls and the incoming telephone number matches the telephone number in the Directory, the 9516CW plays your Call Announcement (Voice Tag) after the first ring:

“Linda calling”

If there is no Call Announcement (Voice Tag) attached to the entry in your Directory, only the number is shown on the display and there is no Call Announcement (Voice Tag). The No Announce option is enabled by default.

Name or Number:

When you choose Name or Number, the 9516CW announces the name through the hands-free speaker if you have recorded a Call Announcement (Voice Tag) for that person in your Directory. If you have not recorded a Call Announcement (Voice Tag) for that person, the 9516CW announces the number through the handsfree speaker.

To enable Name and Number:

1. Press the Set Options key.
2. Use to scroll to number 15 or press to go directly to the item.
3. Press to change.
4. Press twice to go to Name and Number.
5. Press for Name and Number.
6. Press .

For example: If the incoming number is 291-7468, the 9516CW announces “2 9 1 - 7 4 6 8” after the first ring.

Saving a displayed number to the Directory

To save a displayed number to the Directory when not on an active call:

1. Ensure that a number appears on the display. For example, access the Redial List, the Callers List, or a memory key.
2. Press .
3. Press . If the name is displayed with the number, both are now saved in the Directory.
4. If no name is displayed you are prompted to enter one. If you do not want a name, go to step 5. To enter a name, use the dial pad. See **Entering Names** on page 22.
5. Press .
6. Select the mailbox number you want to assign to this person. If you do not select a mailbox, the General Mailbox is assigned. See **Mailboxes** on page 29.
7. Press .
8. Lift the handset and press to record a Call Announcement (Voice Tag). See **Call Announce (Voice Tag)** on page 22.
Note : If you do not want to record a Call Announcement (Voice Tag) go to step 12.
9. Record your Call Announcement (Voice Tag) after the tone.
10. Press .
11. Press to review your recording.
12. Press to end your recording.
13. Press .

Note : If you want to save a displayed long distance number to the Directory, you may have to add digits. Using the dial pad, press and the area code if necessary.

To save a displayed number to the Directory when on an active call:

1. Make or answer a call.
2. Press .
3. Press . If the name is displayed with the number, both are now saved in the Directory.
4. Select the mailbox number you want to assign to this number. If you do not select a mailbox, the General Mailbox is assigned. See **Mailboxes** on page 29.
5. Press . Do not press or else you will hang up your call.

Note : If you want to save a displayed long distance number to the Directory, you may have to add digits. Using the dial pad, press and the area code if necessary.

Saving a memory key entry to the Directory

To save a memory key entry to the Directory:

1. Press the desired memory key. Ensure the live dial pad option is turned off.
2. Press .
3. Press . If the name was displayed with the number, both are now saved in the Directory. If no name is saved, you are prompted to enter one. If you do not want to enter a name, go to step 5. To enter a name, use the dial pad. (See **Entering Names** on page 22.)
4. Select the mailbox.
5. Press .
6. Lift the handset and press to record a Call Announcement (Voice Tag). See **Call Announcement (Voice Tag)** on page 22.
Note : If you do not want to record a Call Announcement (Voice Tag) go to step 11.
7. Record your Call Announcement (Voice Tag) after the tone.
8. Press .
9. Press to review your recording.
10. Press to end your recording.
11. Press To record a personalized greeting for this directory entry, see **Personalized Greetings for Directory entries** , below.

Personalized Greetings for Directory entries

You can record a personal greeting for each number (up to 75) that you have entered in the Directory. When the call is received and the incoming number is matched to a number in the Directory, the caller will hear a personal greeting.[†]

For example, if someone named Peter calls, the message could be:

“Hi Peter. The time for the dinner meeting tonight is now 7:30 pm instead of 6:30 pm.”

To record a personalized greeting:

1. Press .
2. Press to find the name you want or press the first letter of the name using the dial pad. See **Entering Names** on page 22.
3. Press .
4. Lift handset and press .
5. Record your personalized greeting.
6. Press to end your recording.
7. Press .

Note : If you assign a personal greeting to a number that is already assigned to a mailbox, a person dialing that number will hear the Personal greeting, not the General greeting.

[†] You must subscribe to your telephone company for the Calling Line Identification service.

To listen to a personalized greeting:

1. Press .
2. Press to find your greeting.
3. Press .
4. Press .

To change a personalized greeting:

1. Press .
2. Press to find the greeting you want to change.
3. Press .
4. Lift handset and press .
5. Re-record your greeting.
6. Press to end your recording.
7. Press .

To delete a personalized greeting:

1. Press .
 2. Press to find the name you want or press the first letter of the name using the dial pad. See **Entering Names** on page 22.
 3. Press .
 4. While the personalized greeting is playing, press twice.
 5. Press .
- Note:** If you don't have a personalized greeting assigned to a number in your directory, the person calling you from that number will hear the General Mailbox greeting if you have recorded one. If you have not recorded a general greeting, the caller will hear the factory-programmed greeting.

Finding items in the Directory

To find items in the Directory:

1. To see the Directory heading, press .
 2. To see the listings that start with a particular letter, press the appropriate dial pad key. To see the other listings under that letter, press . (For example: takes you to the first "J" listing, then takes you to the next "J" listing. takes you to the first "K" listing). See **Entering Names** on page 22.
Or, to move down and up the list, press or . If you want to scroll steadily, press and hold or . To view which mailbox you have assigned someone or to listen to a voice tag you have recorded for someone, press . To listen to the personalized greeting for a Directory entry, press .
 3. To leave the Directory at any time, press or .
- Note:** If you are on a call while you are viewing the Directory, pressing also drops the call.

Making a call from the Directory

To make a call from the Directory:

1. Press .
2. Press or use the dial pad to find the number you want to dial.
3. Lift the handset or press either or .
4. To end the call, hang up the handset or press .

Editing in the Directory

To edit a Directory entry:

1. Press .
2. Press to find the item you want to edit.
3. To begin editing, press
4. To backspace and erase digits, press . To add digits, use the dial pad.
5. Press .
6. If you do not want to change the name, go to step 7. To change the name, use and the dial pad. See **Entering Names** page 22.
Note: If you edit the wrong item or want to quit without saving changes, press or .
7. Press .
8. Select the mailbox number you want to assign to this person. If you do not select a mailbox, the General Mailbox is assigned. See **Mailboxes** on page 29.
9. Press .
10. If a Call Announcement already exists, the display asks you to press to review it. To record a new Call Announcement (Voice Tag), lift the handset and press twice.
Or, if a Call Announcement does not already exist and you want to record a new one, lift the handset and press record.
Note : If you do not want to record a new Call Announce message, go to step 14. See **Call Announcement (Voice Tag)** on page 22 for more information.
11. Record your Call Announcement (Voice Tag) after the tone.
12. Press .
13. Press to review your recording.
14. Press .
15. Press to review the greeting assigned to this Directory entry. To record a new greeting, press .
16. Pick up the handset and press .
17. Record your personalized greeting after the tone.
18. Press .
19. Press to review your recording.
20. Press .

Deleting items from the Directory

To delete individual items:

1. Press .3. Press
2. Press to find the item you want to delete.
3. Press twice. You are still in the Directory.
4. Press or to exit the Directory at any time.

Mailboxes

The 9516CW is equipped with 12 mailboxes for individual message storage. It uses Calling Line Identification information to send the incoming calls to the assigned mailboxes automatically.[†] When an incoming number matches an entry in the Directory, the call is routed to the assigned mailbox. If there is no match to a Directory entry, the calls are routed to the General mailbox.

When an incoming call is routed to a mailbox, that caller hears the greeting recorded for that mailbox. This greeting is called a mailbox greeting. You can record a different mailbox greeting for each of the mailboxes. If you do not record a greeting for a particular mailbox, the greeting recorded for the General mailbox is used. For more information about mailbox greetings, see **Mailbox Greetings** on page 30.

There are three classes of mailboxes:

Normal - The 9516CW plays the mailbox greeting and then callers are given an opportunity to leave a message.

Announce Only - A mailbox greeting is played to the caller, but the caller is not given an opportunity to leave a message. This type of mailbox provides information to the caller (for example, a greeting that states hours the business is open).

Ring Through - The callers hear a tone indicating that they are on hold, but the 9516CW rings to let you know someone is in that mailbox. If you do not answer after four rings, the General Mailbox Greeting is played. The 9516CW plays a message to the caller that no one is available to take their call and to leave a message. This type of mailbox is used only with the Automated Attendant feature. See **Automated Attendant** on page 52.

All mailboxes default to the Normal class. To change the class of the mailbox, you must use the editing function below. Note that you cannot change the class of the General and Special mailboxes.

Editing the mailbox name and class:

1. Press .
2. Press to find the mailbox or use the dial pad to enter the mailbox number.
3. Press to start editing the mailbox.
4. Use the dial pad to enter the name of the mailbox. See **Entering names** on page 22.
5. Press .
6. Choose the mailbox class. Press for a Normal mailbox, press for an Announce Only mailbox, or press for a Ring Through mailbox.
7. Press .

Mailbox Greetings

Each of the 12 mailboxes on the 9516CW can have a specific greeting assigned to it. These greetings are called Mailbox greetings.

Mailbox greetings allow you to assign a particular greeting to one or more callers. The caller's telephone number must match one of the numbers in the Directory and be assigned to a mailbox. When a call is received from callers assigned to a mailbox, they will hear the greeting assigned to that mailbox.

For example, John entered the numbers of his baseball teammates into his Directory and assigned them all to one particular mailbox. Then he recorded a greeting for that mailbox that contained information about baseball practice. Now, when any of his teammates calls from a number he has stored in his Directory, the 9516CW plays the following message:

"Hi team, the baseball practice has been rescheduled to Friday. Leave me a message to let me know if you can still attend."

The 9516CW plays a factory-recorded General Greeting unless you record your own General Greeting. Each mailbox will contain the General Greeting (the factory-recorded one or your own recorded one) until you record a unique mailbox greeting. You record mailbox greetings in the Greeting list.

Sometimes callers choose not to listen to your greeting before recording a message. They can press to skip your greeting and leave their message immediately.

To record your greeting:

1. Press .
2. Press to find the greeting you want to record.
3. Press .
4. Lift the handset and press again.
5. Record your greeting.
6. Press to end your recording.
7. Press .

To listen to your greeting:

1. Press .
2. Press to find your greeting.
3. Press .
4. Press .

To change your greeting:

1. Press .
2. Press to find the greeting you want to change.
3. Press .
4. Lift the handset and press again.
5. Re-record your greeting.
6. Press to end your recording.
7. Press .

To delete your greeting:

1. Press .
2. Press to find the greeting you want to delete.
3. Press .
4. Press again to confirm deletion of your greeting.
5. Press .

Note: If you delete your General mailbox greeting, callers will hear the factory-programmed greeting.

Assigning people to a Mailbox

A person's telephone number must be entered into the Directory before you can assign that person to a mailbox. For more information on Directory entries, see **Creating a New Directory Entry** on page 21.

You can assign a mailbox to a group of family members or colleagues. Every person in this group will hear the same greeting. Also, only messages left by this group are stored in this mailbox.

To assign people to a mailbox:

1. Press
2. Press to find the person you are assigning to the mailbox.
3. Press to begin editing.
4. Press twice.
5. Use the dial pad to enter the mailbox number.
6. Press twice to end.
7. Press .

Follow steps 2 through 6 until you have all the people you want assigned to the mailbox.

Callers who do not appear in the Directory can also be directed to a mailbox. For callers to leave a message in a specific mailbox, they must enter the mailbox number before they record their message. For this to work properly you must inform the caller which number to press to get the right mailbox.

For example, you may have three people who share the 9516CW and they want to have their messages stored in separate mailboxes.

“Hello, we are unable to take your call right now. To leave a message for Bob, press ; to leave a message for John, press ; to leave a message for Adam, press .

When a caller who wants to speak to Bob presses that caller's message is stored in mailbox 1.

Callers List

Using the Callers List

The 9516CW stores up to 75 calls and messages in the Callers List. Your telephone logs callers' numbers (and names if available), when they last called, the number of times they tried to reach you and the messages they left.[†] You use the Callers List to access your stored calls and messages. See **Callers List display messages** on page 59 for a description of the display messages and icons.

When you have a new message, **✕ New messages** appears on the display. For more information about messages, see **Messages** on page 16. If the telephone number of the incoming call matches a number that you have programmed with a name in a memory key or the Directory, the Callers List shows the name first and then the number. You can choose to log either all incoming calls or only unanswered calls in the Callers List.

Setting up the Callers List

You can program the 9516CW to record only unanswered calls or all incoming calls. The default is to record all calls.

To change the Callers List:

1. Press the Set Options key.
2. Use **↓** **↑** to scroll to number 8 or press **0** **8** to go directly to the item.
3. Press **✕** and follow the instructions on the display to change the Callers List.
4. Press **RLS**.

Finding items in the Callers List:

To find items in the Callers List:

1. To see the Callers List heading, press **Callers**.
2. To see the first new caller in the list, press **↓** **□** twice.
To move down and up the list, press **↓** **↑**.
If you want to scroll steadily, press and hold **↓** **↑**.
3. To leave the Callers List at any time, press **Callers** or **RLS**.
Note: If you are on a call while viewing the Callers List, pressing **RLS** also drops the call.

[†] You must subscribe to your telephone company for the Calling Line Identification service.

Making a call from the Callers List

To dial a number in the Callers List:

1. Press .
2. Use to find the number you want to dial.
3. Lift the handset or press either or .
4. To end the call, hang up the handset or press .

Note : When you finish the call, the display returns to the Callers List.

If you call a number from the Callers List and you do not get connected, you may have to edit the number (for example, the number may be long distance and you may have to add "1"). See **Editing in the Callers List** below.

Editing in the Callers List

To edit a number in the Callers List:

1. Press .
2. Use to find the item you want to edit.
3. Press any key on the dialpad to begin editing.
4. To add digits, use the dial pad. To erase one digit to the right of the cursor, press . To erase one digit to the left of the cursor, press .
- Caution:** The Callers List does not save changes. If you plan to call the number again, copy it to the Directory or a memory key. See **Saving Displayed Numbers from the Callers List** on page 35.
5. To dial the edited number, lift the handset or press either or .

To have the Callers List show local numbers without the area code and internal numbers as extensions, see **Entering area codes** on page 46.

To dial back a long distance number in the Callers List:

1. Press .
2. Use to find the item you want to edit.
3. Using the dial pad, press and the area code if necessary.
4. To dial the edited number, lift the handset or press either or .
5. If you want to save the number to the directory, press . See **To save a displayed number to the Directory when not on an active call:** on page 25.

Listening to messages in the Callers List

To listen to messages in the Callers List:

1. Press .
2. Use to find the message you want to hear.
3. Press .
4. Press when you have finished listening to the message.

To make the message new in the Callers List:

1. Press .
2. Use to find the message that you want to make new.
3. Press . The indicator light begins flashing and **N** appears on the display. Once you exit the Callers list, ✳ New message → appears on the display indicating a new message.

Saving displayed numbers from the Callers List

To copy a number from the Callers List to the Directory or to a memory key:

1. Press .
 2. Use to find the item you want to copy.
 3. Press .
 4. Press or the memory key where you want to store the number.
 5. If no name is displayed, you are prompted to enter one. To enter a name, use the dial pad. See **Entering Names** on page 22. If you do not want to enter a name, go to step 7.
 6. Press .
 7. Use the dial pad to enter a mailbox number. See **Assigning people to a Mailbox** on page 32.
 8. Press .
 9. Lift the handset and press to record the name. See **Call Announce (Voice Tag)** on page 22.
 10. Record the name.
 11. Press .
 12. Press to review the recording.
 13. Press .
- Note** : Omit steps 7 through 12 if you do not want to assign a mailbox or record a name from the Callers List.
14. To leave the Callers List at any time, press or .

Deleting items from the Callers List

To delete an item in the Callers List:

1. Press .
2. Use to find the item you want to delete.
3. Press twice.
You are still in the Callers List.
4. To leave the Callers List at any time, press or .

To delete all items in the Callers List:

1. Press .
2. Press once.
3. Press .
4. Press again to confirm deletion of the entire Callers List.
5. Press .

Memory keys

Saving numbers and names to memory keys

You can save the numbers and names of your customers, business associates, or anyone you call frequently in 9516CW's five memory keys. You can also assign those numbers Call Announcements (Voice Tags) and personal greetings. See **Directory** on page 20 for more information on saving additional numbers and names to the Directory.

Note: To achieve the best sound quality for recorded greetings and Call Announcements, it is recommended that you record by speaking into the handset instead of the handsfree microphone.

To save a new name and number to a memory key:

1. Press .
2. Press the desired memory key.
Note: If you attempt to save to a memory key that already contains an entry, the message, *Key in use, Delete to change,* appears. You must first delete the old entry before saving a new one. See **Deleting memory keys** on page 40 for more information.
3. Enter the number using the dial pad.
4. Press . Only the number is stored at this point.
5. If you do not want a name, go to step 6. To enter a name, use the dial pad. See **Entering Names** on page 22.
6. Press .
7. Select the mailbox number you want to assign to this person. If you do not select a mailbox, the General Mailbox is assigned. See **Mailboxes** on page 29.
8. Press .
9. Lift the handset and press to record a Call Announcement (Voice Tag). See **Call Announce (Voice Tag)** on page 22.
Note : If you do not want to record a Call Announce message, go to step 13.
10. Record your Call Announcement (Voice Tag) after the tone.
11. Press .
12. Press to review your recording.
13. Press .
14. Press .

Saving from the display to memory keys

To save from the display to a memory key when not on an active call:

1. Ensure that a number is on the display. (For example, access the Redial List or Callers List.)
2. Press .
3. Press the desired memory key. If the name was displayed with the number, both are now saved in the memory key.
4. If no name is displayed, you are prompted to enter one. If you do not want to enter a name, go to step 5. To enter a name, use the dial pad. See **Entering Names** on page 22.
5. Press .
6. Select the mailbox number you want to assign to this person. If you do not select a mailbox, the General Mailbox is assigned. See **Mailboxes** on page 29.
7. Press .
8. Lift the handset and press to record a Call Announcement (Voice Tag). See **Call Announce (Voice Tag)** on page 22.
Note : If you do not want to record a Call Announce message, go to step 13.
9. Record your Call Announcement (Voice Tag) after the tone.
10. Press .
11. Press to review your recording.
12. Press to end your recording.
13. Press .
14. Label the memory key. See the diagram **Labeling the memory keys** on page 38.
Note: To record a personalized greeting for a memory key entry, see **Personalized Greetings for Memory keys** on page 38.

Note : Some of the memory keys may be factory programmed. These keys are locked and cannot be erased or reprogrammed.

To save a displayed number to a memory key when on an active call:

1. Make or answer a call.
2. Press .
3. Press the desired memory key. If the name is displayed with the number, both are now saved in the memory key.
4. Select the mailbox number you want to assign to this number. If you do not select a mailbox, the General Mailbox is assigned. See **Mailboxes** on page 29.
5. Press . Do not press or else you will hang up on your call.

Note : If you want to save a displayed long distance number to a memory key, you may have to add digits. Using the dial pad, press and the area code if necessary.

Note : Some of the memory keys may be factory programmed. These keys are locked and cannot be erased or reprogrammed.

Recording a Call Announcement (Voice Tag) for a memory key

You can also record Call Announcement (Voice Tag) to a programmed memory key. See **Call Announcement (Voice Tag)** on page 22 for more information.

Labeling the memory keys

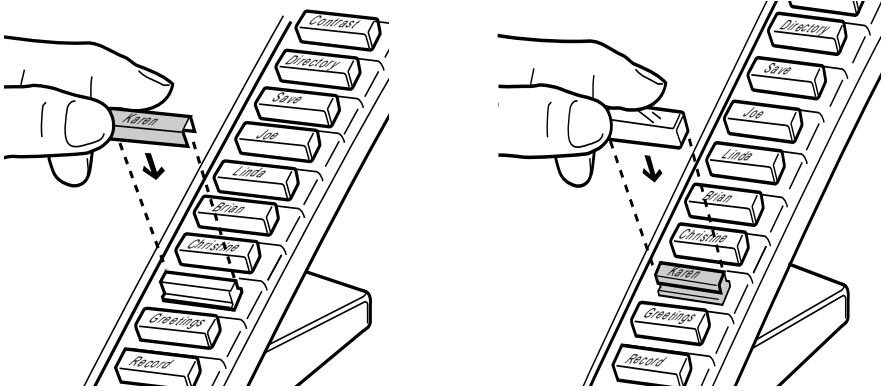

After programming the memory keys, label them with the supplied blank labels and key caps.[†]

Personalized Greetings for Memory keys ††

You can record a personal greeting for the numbers stored in your memory keys. When the call is received and the number is matched to a number in a memory key, the caller will hear the personal greeting you have recorded.

For example, if someone named Peter calls, the message could be:

“Hi Peter. The time for the dinner meeting tonight is now 7:30 pm instead of 6:30 pm.”

Note : If you assign a personal greeting to someone who is already assigned to a mailbox, that person will hear the Personal Greeting instead of the mailbox greeting.

To record a personalized greeting for a memory key:

1. Press the desired memory key.
2. Press **Record**.
3. Lift handset and press **Record**.
4. Record your personalized greeting.
5. Press **Save** to end your recording.
6. Press **Fls**.

[†] Keep key caps and the sliding panel away from small children. These small parts may come off the telephone if it is dropped.

^{††} You must subscribe to your telephone company for the Calling Line Identification service for this feature to work.

To listen to a personalized greeting stored in a memory key:

1. Press the desired memory key.
2. Press .
3. Press .

Note: The Live dial pad option must be turned off to listen to greetings in memory keys. See **Selecting the dial pad mode** on page 45 for more information.

To change a personalized greeting stored in a memory key:

1. Press the desired memory key.
2. Press .
3. Lift handset and press .
4. Re-record your greeting.
5. Press to end your recording.
6. Press .

Note: The Live dial pad option must be turned off to edit memory keys. See **Selecting the dial pad mode** on page 45 for more information.

To delete a personalized greeting stored in a memory key:

1. Press the desired memory key.
2. Press .
3. While the personalized greeting is playing, press twice.
4. Press .

Note: The Live dial pad option must be turned off to edit memory keys. See **Selecting the dial pad mode** on page 45 for more information.

Making calls from memory keys

To call from a memory key:

1. Lift the handset or press either or .
2. Press the memory key with the number you want to dial out.

To predial from a memory key:

1. Press the memory key with the number you want to dial out.
2. Lift the handset or press either or .

Note : If the Live dial pad option is turned on, you do not have to lift the handset or press any other button. Pressing the memory key will automatically dial the number and put the telephone in Handsfree mode.

Editing memory keys

To edit a memory key:

1. To see its contents, press the memory key.
2. Press .
3. If you do not want to change the number, go to step 4. To backspace and erase digits, press . To add digits, use the dial pad.
4. Press .
5. If you do not want to change the name, go to step 6. To add letters, use the dial pad. See **Entering Names** on page 22. To erase letters, press .
6. Press .
7. Select the mailbox number you want to assign to this person. If you do not select a mailbox, the General Mailbox is assigned. See **Mailboxes** on page 29.
8. Press .
9. If a Call Announcement already exists, the display asks you to press to review it. To record a new Call Announcement (Voice Tag), lift the handset and press twice.
or
If a Call Announcement does not already exist and you want to record a new one, lift the handset and press record.
Note : If you do not want to record a new Call Announce message, go to step 13. See **Call Announcement (Voice Tag)** on page 22 for more information.
10. Record your Call Announcement (Voice Tag) after the tone.
11. Press .
12. Press to review your recording.
13. Press .
14. Press .

Note: The Live dial pad option must be turned off to edit memory keys. See **Selecting the dial pad mode** on page 45 for more information.

Deleting memory keys

Before you can save to a memory key that already contains a saved entry (a name, number, feature code, etc.), you must first delete the old contents of the memory key.

To delete a memory key:

1. To see its contents, press the memory key.
2. To erase, press twice.

Note: The Live dial pad option must be turned off to edit memory keys. See **Selecting the dial pad mode** on page 45 for more information.

Saving features in memory keys †

For easy access, you can save the feature codes of telephone company services in your memory keys. This works well with network features such as Call Forwarding, Call Waiting and Call Return. Some features require an On and Off code in two separate keys, while other features are stored in only one key. The following procedures show you how to save both On and Off codes.

To save a feature On code:

1. Press .

2. Press the desired memory key.
Note: If you attempt to save to a memory key that already contains an entry, the message, *Key in use, Delete to change*, appears. You must first delete the old entry before saving a new one. See **Deleting memory keys** on page 40.

3. Enter the telephone company feature code for turning the feature on.† Read the display to confirm the number.

4. Press again.

5. Enter the feature name using the dial pad. See **Entering Names** on page 22.

6. Press three times to save the name and skip the mailbox and voice tag prompts.

7. Label the memory key. See the diagram on page 38.

To save a feature Off code:

1. Press .

2. Press the desired memory key.
Note: If you attempt to save to a memory key that already contains an entry, the message, *Key in use, Delete to change*, appears. You must first delete the old entry before saving a new one. See **Deleting memory keys** on page 40.

3. Enter the telephone company feature code for turning the feature off.† Read the display to confirm the number.

4. Press again.

5. Enter the feature name using the dial pad. See **Entering Names** on page 22.

6. Press three times to save the name and skip the mailbox and voice tag prompts.

7. Label the memory key. See the diagram on page 38.

†**Note:** Contact your local telephone company for the appropriate feature codes.

Using feature keys

When a memory key is programmed with a feature code, you can use the memory key to activate or deactivate the feature.

To turn a feature on or off:

1. Press the memory key where you stored the desired feature. The display shows the feature name and code.

 2. Lift the handset or press either or .
- The feature code is dialed out, which turns the feature on or off.

Note : If the Live dial pad option is turned on, you do not have to lift the handset or press any other button. Pressing the memory key will automatically dial the feature code and put the telephone in Handsfree mode.

† You must subscribe to your telephone company for Custom Calling Features.

Saving a feature and light to memory keys

You can make the set indicator light come on when you turn a feature on and go off when you turn that same feature off. You can only do this with one feature, and the feature must have separate On and Off codes (such as Call Forwarding).

For example, you may want the light to remind you that you have turned Call Forwarding on. To do this, use one key to turn the indicator light on when you activate the feature. Use the second key to turn the indicator light off when you deactivate that same feature. The following procedure shows you how to program a Feature Light On and Off key.

To save a FeatureLight On key:

1. Press . Do NOT select a memory key yet.
2. To program the light on, press .
3. Press the desired memory key.
Note: If you attempt to save to a memory key that already contains an entry, the message, *Key in use, Delete to change*, appears. You must first delete the old entry before saving a new one. See **Deleting memory keys** on page 40 for more information.
4. Enter the telephone company feature code for turning the feature on.[†]
5. Press .
6. Read the display to confirm the number.
7. Label the memory key.
See the diagram on page 38.

[†]**Note:** Contact your telephone company for the appropriate feature codes.

To save a FeatureLight Off key:

1. Press . Do NOT select a memory key yet.
2. To program the light off, press .
3. Press the desired memory key.
Note: If you attempt to save to a memory key that already contains an entry, the message, *Key in use, Delete to change*, appears. You must first delete the old entry before saving a new one. See **Deleting memory keys** on page 40 for more information.
4. Enter the telephone company feature code for turning the feature off.[†]
5. Press .
6. Read the display to confirm the number.
7. Label the memory key.
See the diagram on page 38.

Using Feature Light keys

To turn a feature and its light on or off:

1. Press the memory key where you stored the FeatureLight.
The display shows *FeatureLight ON* or *FeatureLight OFF*.
 2. Lift the handset or press either or .
- The feature and light turn on or off. (When the feature and light are on and you are not using the telephone, the display shows *Feature ON* as a reminder).

Note : If the Live dial pad option is turned on, you do not have to lift the handset or press any other button. Pressing the memory key will automatically dial the feature code and put the telephone in Handsfree mode.

Advanced Features

Adding a timer key

You can program any of the memory keys to be a timer key.

To add a timer key:

1. Press the Set Options key.
2. Use to scroll to number 4 or press to go directly to the item.
3. Press to add a timer key.
4. Press a memory key.
5. Press .
6. Press .
7. Label the timer key. See the diagram on page 38.

Using the call Timer

The timer key is used to time the length of a call.

To show the timer on the display:

1. Make or answer a call. The timer starts running automatically.
2. Once on the call, press the Timer key. The display shows the running time of the call. Press the Timer key again to return the display to the date and time.
3. When the call is over, hang up the handset or press . The timer stops counting. To show the elapsed time of the most recent call (or last call) when you are not on a call, press the Timer key.

Deleting a timer key

To delete the timer key:

1. Press the timer key.
2. Press twice.

Adding a page key

You can program any of the memory keys to be a page key. If the page key is assigned, the 9516CW is able to receive and initiate page transmissions.

To add a page key:

1. Press the Set Options key.
2. Use to scroll to number 21 or press to go directly to the item.
3. Press to add a page key.
4. Press a memory key.
5. Press .
6. Press .
7. Label the page key. See the diagram on page 38.

Note : For proper operation of the Page feature, all phones must have Page keys assigned.

Using the page

The page feature of the 9516CW allows you to send a page message to other 9516CW telephones, to an external speaker within your office, or to other page-compatible 9000 series telephones (such as the 9417CW). Before you can use this feature, you must program one memory key on each telephone in the paging network to be the page key. Also, page lines must be connected between all of the 9000 series telephones. See **Installing the Page Lines** on page 45 for more information on connecting the page lines.

When the Page feature is activated, page lines are installed and the Call Announce Option on your telephone is set to either “Name Only” or “Name or Number”, either the Call Announce (Voice Tag) or the number of the caller who phones your telephone will be heard over the other Page-enabled telephones and any attached external speakers. For example, if you have Joe’s number stored in your Directory with the Call Announce, “It’s Joe calling,” and Joe calls your Page-enabled telephone, all phones in the paging network will hear, “It’s Joe calling,” before they hear Joe’s page message.

To send a page message:

1. Lift the handset.
2. Press the page key and speak into the microphone or handset.
3. Replace the handset or press **[RIS]** to end a page.

Deleting a page key

To delete a page key, you must first reprogram the key to be a memory key. You can then delete the memory key.

To delete a page key:

First, reprogram the key to be a memory key:

1. Press **[Save]**.
2. Press the page key.
3. Press **[7]** to begin re-programming the page key to be a memory key.
4. Press **[Save]** four times to skip the number, name, mailbox and voice tag prompts. The page key has been changed to a memory key.

Second, clear the contents of the memory key:

5. Press the page key.
6. Press **[Delete]** twice.

Note: The Live dial pad option must be turned off to delete a page key. To save a number into the memory key, refer to **Memory Keys** on page 38.

Installing the page lines

The page lines must be connected in parallel with each other on pins 1 and 6 of Jack #2 as shown below:

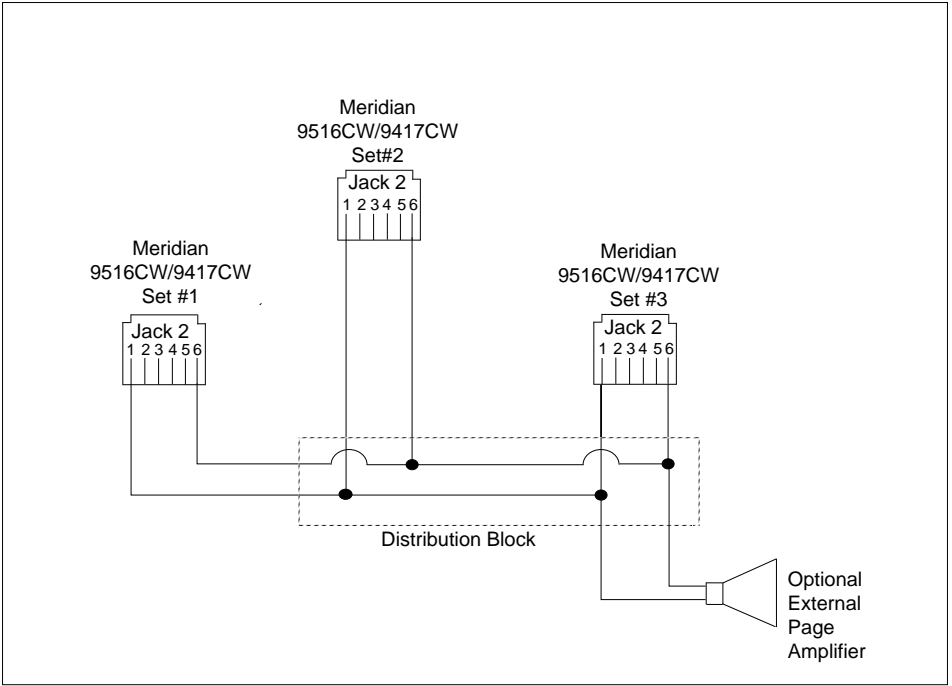

Note : A separate jack and a 6 conductor line cord is required to connect page lines. This cord is not supplied with the 9516CW telephone. Contact your telephone company representative to have page lines connected to your telephones.

Selecting the dial pad mode

When you select the dial pad mode, you are turning the Live dial pad option on or off. With Live dial pad on, the telephone automatically dials out and turns on Handsfree as soon as you press a dial pad key or a memory key. When Live dial pad is off, the telephone is in regular or predial mode. This means after you dial the telephone number you must lift the handset or press either or before the telephone number is dialed. The Live dial pad option default is off.

To select the dial pad mode:

1. Press the Set Options key.
2. Use to scroll to number 5 or press to go directly to the item.
3. Press to change the dial pad mode.
4. Press .

Entering area codes

When you enter an area code or prefix using this feature, your 9516CW telephone will remove that code or prefix from incoming numbers. For example, if you enter your area code into this option, all calls in your area code will appear in the Callers List with the area code stripped off (the area code will appear in brackets after the number). This feature may make it easier to identify local calls. You can enter three separate area codes or prefixes, each up to seven digits long.

To enter area codes and prefixes:

1. Press the Set Options key.
2. Use to scroll to number 7 or press to go directly to the item.
3. Press .
4. Enter the area code or prefix and press .
Repeat this step for each area code or prefix you want to enter.
5. Press .

To delete or change an area code or prefix:

1. Press the Set Options key.
2. Use to scroll to number 7 or press to go directly to the item.
3. Press . The first area code is displayed. If this is the number you want to delete or change, go to step 5.
4. Press until you see the number you want to change or delete.
5. Press to backspace and delete or change the area code or prefix.
6. Press .
7. Press .

Entering Dialing Restrictions

Dialing Restrictions are used to prevent certain numbers from being dialed out. There are three codes (up to seven digits each) that can be programmed to prevent certain numbers from being dialed. If you attempt to dial a number that matches the restricted digits, the message, **Restricted number**, appears on the display. For example, if you entered the codes below:

1st code> 0

2nd code>1

3rd code> 411

Any number beginning with 0, 1 or 411 could not be dialed from the telephone. However, the number 555-0411 could be dialed because it does not begin with the restricted digits.

To enter Dialing Restrictions:

1. Press the Set Options key.
2. Use to scroll to number 23 or press to go directly to the item.
3. Press .
4. Enter the digits you want restricted and press .
Repeat this step for each dialing restriction you want to enter.
5. Press .

To delete or change Dialing Restrictions:

1. Press the Set Options key.
2. Use to scroll to number 23 or press to go directly to the item.
3. Press .
4. Press to back space and delete or change restricted digits.
5. Press . Repeat steps 4 and 5 for the restricted digits that you want to delete.
6. Press .

Important: Care must be taken when you are restricting numbers that start with 9. If you enter 9, 91, or 911 as one of the dialing restrictions, you will not be able to dial the emergency services number 911.

The Security Numbers feature

The 9516CW is equipped with a Security Numbers feature to keep selected numbers private when you dial. When you have entered a security number using this option, your telephone does not display or store the digits that you dial after that security number. Instead, the numbers that follow the security number are replaced with the * symbol on the display. You can secure up to five 12-digit numbers.

For example, Joe enters 291-9000 as a security number through the Set Options list. His Voice Mail number is 1234 and his password is 5678. To access his messages, Joe dials 291-9000 1234 5678. Because the Voice Mail number and password follow the security number, the display shows 291-9000 *****, and Joe's password is not displayed or stored in the Redial List. For more information on the Redial List, refer to **Using the Redial List** on page 7.

To enter security numbers:

1. Press the Set options key.
2. Use to scroll to number 25 or press to go directly to the item.
3. Press .
4. Using the dial pad, enter the security number.
5. Press to save your number.
Repeat steps 4 and 5 for each secure number you want to enter.
6. Press .

To delete or change a security number:

1. Press the Set options key.
2. Use to scroll to number 25 or press to go directly to the item.
3. Press .
4. Press until you find the number you want to change or delete.
5. Press to backspace and simply delete the secure number, or delete the secure number and use the dial pad to enter the changed number.
6. Press .
7. Press .

The Fax Switch

The Fax Switch feature allows you to have two telephone numbers on one incoming line. There is one telephone number for the line and another telephone number for a Fax Switch peripheral (e.g. fax machine).

To use the Fax Switch, you must subscribe to your telephone company for Distinctive Ringing[†]. The telephone company will then provide you with an additional telephone number (for your Fax Switch peripheral) which will have a slightly different ring. The 9516CW will use the two ring types to determine whether an incoming call is for the telephone or the peripheral. The peripheral should be set to answer after three or more rings.

Note: If Long Distance Ringing[†] is available in your area, long distance calls will be sent to the Fax Switch peripheral. Also, you cannot use the Fax Switch feature and the Special Greeting feature at the same time.

The 9516CW must be configured so the Fax Switch peripheral is connected to pins 3 and 4 of jack number 2. See **Connecting an optional fax machine or modem** on page 4 for more information.

Note: If you subscribe to your telephone company for Call Waiting services, your Fax Switch peripheral may lose data or get disconnected if someone calls while your fax is receiving data. We recommend that you do not subscribe to the Call Waiting service from your telephone company if you are using the Fax Switch feature.

Incoming Calls

The first ring of an incoming call will ring at the 9516CW and the Fax Switch peripheral. The 9516CW uses this ring to identify which device the call is intended for. If it is a normal ring, the call is routed to the 9516CW and the Fax Switch peripheral stops ringing and is disconnected. If it is a distinctive ring, the call is rerouted to the Fax Switch peripheral and the 9516CW stops ringing.





Outgoing Calls

When the Fax Switch peripheral is idle, the 9516CW can be used as a normal line. When the Fax Switch peripheral is in use, the set indicator light and **Extension in use** appears on the display.

Setting the Fax Switch

You can program the telephone to enable or disable the Fax Switch feature.

To set the Fax Switch:

1. Press the Options key.
2. Use   to scroll to number 20 or press .
3. Press  to enable or to disable the Fax Switch.
4. Press .

Note: For proper operation of this feature, all of the 9516CW telephones/peripherals must have the Fax Switch enabled. By default, the Fax Switch is off.

[†] The actual name for the Distinctive Ringing service varies from area to area. This service may also be known as *Ident-a-call*, *Ident-a-ring*, *Teen Service*, *Signal Ring*, *Custom Ringing* or *Long Distance Ringing*.

Copying the Directory to another 9516CW telephone

The contents of the Directory of one 9516CW telephone can be copied into the Directory of another 9516CW. You can save a lot of programming time by copying the contents of a completed Directory to another Directory instead of entering the names and numbers again. The contents of the Directory can also be transferred into any other 8000 & 9000 series telephone that supports Directory transfer. (For example, the 9417CW).







While the Directory is being transferred, the telephone is out of service.

Note : Both 9516CW telephones must have separate telephone numbers.

To copy the Directory to another 9516CW telephone:

Steps 1 to 3 must be completed on both 9516CW telephones.

Note : You can only transfer the Directory to one 9516CW at a time.

1. Press the Set Options key.
2. Use   to scroll to number 24 or press  to go directly to the item.
Note : Once you have enabled the Data transfer option, you have four minutes to begin the data transfer before the option times out.
3. Follow the instructions on the display to begin the Directory transfer.
4. On the 9516CW telephone you are copying the Directory from, use handsfree mode to dial the telephone number of the other 9516CW. The receiving 9516CW automatically answers the call after the first ring and begins copying the data being sent. The display shows a message indicating that the Directory information is being sent and received.
Note : The handset must remain in the cradle while the Directory is being transferred. During the transfer, press the left side of    to turn down the volume.
5. The display shows: **Data transfer complete** when the Directory Transfer is complete. If the transfer is unsuccessful, the display shows: **Data transfer aborted**.

Note : To end the Directory Transfer at any time, press .

If the Directory on the telephone receiving the information fills before the Directory Transfer is finished, the rest of the Directory items are not sent. For example, if the telephone receiving the information already has 50 items in its Directory, only the first 25 Directory items are transferred.

When you transfer directory items from one 9516CW to another, any information such as call announcements/voice tags, mailbox greetings or mailbox numbers are **not** transferred. You need to re-enter this information to the receiving 9516CW.

Note : If you subscribe to the Call Waiting service from your telephone company and someone calls while the Directory Transfer is in progress, the transfer may be corrupted by the Call Waiting tone.







Call Blocking

The Call Blocking feature detects “Private Name” and/or “Private number” incoming calls. When “Private Name” or “Private number” calls are received, Call Blocking directs the call to be answered after the first ring by the answering machine. The caller will hear the Private Greeting if you have recorded one. See **The Private Greeting** on page 15 for more information. The Call Blocking option default is off.

For example:



You may be receiving nuisance calls from “Private Number” and/or “Private Name” callers. Enabling Call Blocking sends these types of calls to the answering machine after the first ring instead of interrupting you.

To enable call blocking:

1. Press the Set Options key.
2. Use   to scroll to number 16 or press   to go directly to the item.
3. Press  to enable or disable call blocking.
4. Press .

Using a headset







To connect the headset, you must disconnect the handset and attach the headset to the jack labeled .

You cannot use Handsfree when the headset mode is enabled. The  key is used to answer the call. Press  when the call is finished.

Note: When the headset mode is enabled, the handset must remain in the cradle. The headset mode default is off.

Changing the headset mode

To change the headset mode:

1. Press the Set Options key.
2. Use   to scroll to number 22 or press  .
3. Press  to enable or disable the headset mode.
4. Press .

We suggest contacting the manufacturers Brock Telecom, UNEX, ACS Communications or Plantronics for compatible headsets/amplifiers.

Automated Attendant

The Automated Attendant feature of the 9516CW works as the receptionist for a small business. When activated, the Automated Attendant prompts provide a list of options so your callers can:

- receive information
- leave messages
- be connected to an operator

The Automated Attendant feature provides your callers with commands to use each of these options. The callers press the key on the dial pad associated with the option they want to activate.

When the Automated Attendant feature is turned on, callers always hear the Automated Attendant greeting, even if you have recorded a personal greeting. Callers cannot skip the Automated Attendant greeting by pressing #.

Example of Automated Attendant

The following example explains how to set up the mailboxes and greetings to use the automated attendant.

Joe's Bistro has some customers who prefer to use English and some who prefer to use Italian. For this reason, Joe has decided to change his automated attendant to include both languages.

The first thing Joe did was subscribe to his telephone company to get Distinctive Ringing service. This gives him one telephone number for his English customers and one for his Italian customers.

Next, Joe recorded his General Mailbox Greeting:

“Thank you for calling Joe's Bistro. For today's lunch specials, press 1; for our business hours, press 2; to leave a message, press 3; to speak to Joe, press 4.”

Then Joe recorded his Special Mailbox Greeting to take advantage of his Distinctive Ring feature. This greeting is in Italian and tells the customers to press 5 for lunch specials, 6 for business hours, 7 to leave a message and 8 to speak to Joe.

Joe then set up his mailboxes as shown in this table.

Mailbox #	Mailbox type	Greeting
1	Announce	"The special for today is corned beef on rye."
2	Announce	"Our business hours are 7:00 am to 9:00 pm on week days and 11:00 am to 11:30 pm on Saturdays."
3	Normal	"Please leave a message after the tone and I will get back to you as soon as possible."
4	Ring through	The caller will hear a tone and the telephone will ring to let Joe know that someone would rather speak to him than leave a message. If Joe does not answer this call, the following message is played: "I'm sorry, but I cannot answer the phone right now. Please leave a message after the tone and I will get back to you as soon as possible."
5	Announce	Same as mailbox 1, but greeting is in Italian.
6	Announce	Same as mailbox 2, but greeting is in Italian.
7	Normal	Same as mailbox 3, but greeting is in Italian.
8	Ring through	Same as mailbox 4, but greeting is in Italian.

Enabling or disabling the Automated Attendant feature is done through the Set Options list.

To enable or disable the Automated Attendant:

1. Press the Set Options key.
2. Press \downarrow \uparrow to scroll to number 19 or press \uparrow 9 to go directly to the item.
3. Press \otimes to enable or disable Automated Attendant.
4. Press $\overline{R/S}$.

When Automated Attendant is enabled all calls are answered by either your General, Special or Private Greetings. If your caller does not press any of the dial pad keys after the greeting has played, the greeting will play a second time and the caller is given the opportunity to leave a message. The Automated Attendant default is off.

Remote Notification

You can program the 9516CW to call you at a different telephone number when there is a new message for you.

If the Remote Notification call is not answered, the 9516CW will attempt to call you five more times. The Remote Notification default is off.

To enable or disable Remote Notification:

1. Press the Set Options key.
2. Press to scroll to number 17 or press to go directly to the item.
3. Press to enable or to disable remote notification.
4. Press .

To set the remote Notification Number:

1. Press the Set Options key.
2. Press to scroll to number 18 or press to go directly to the item.
3. Press .
4. Using the dial pad enter the Remote Notification number.
5. Press .
6. Press .

Note : You should enable the Remote Notification feature from the number you want to be contacted at to avoid missing messages.

The 9516CW audibly alerts the remote location to remind them that the Remote Notification feature is still enabled. Remote Notification can be disabled by the remote location by pressing .

For example:

If someone comes to visit you and uses your telephone number as the Remote Notification number and forgets to disable it before leaving, you can disable Remote Notification by pressing .

If you have set up your 9516CW to call a paging system you must insert a pause between the pager number and the number to be paged. Pressing inserts a three second pause between the two numbers. Depending on the type of paging service, multiple pauses may have to be inserted.

For example:

If the pager number is 222-1234, and the number to be paged is 222-5678:

Dial 222-1234, press 222-5678.

Remote Access

You can access the 9516CW from another telephone number to retrieve your messages and/or call log information.

Call your 9516CW and listen to the greeting. During the greeting press *****. The 9516CW prompts you to enter your password. Using the dial pad, enter your four digit password (as shown below). After you have entered the correct password, the main menu prompts you to press a dial pad key to select the option you want. Select the option and follow the voice prompt. See the Remote Access chart on the next page for more information about the main menu prompts.

For example:

Press **1** for Callers:

- You can listen to the numbers in your callers list, the date and time calls were logged and any messages that you have. You can delete, replay, and renew your messages.

Press **2** for Directory:

- You can listen to names and numbers that you have entered in your Directory or change your personalized Greeting.

Press **3** for Greetings:

- You can listen to or change the General, Special, Private or Mailbox greetings that you have recorded.

Note : You cannot access individual mailboxes remotely.

Press **4** for Options:

- You can turn the answering machine on or off, enable or disable the Toll Saver, turn Remote Notification on or off, enter your Remote Notification number.

Press **5** to record a memo.

You set your password for remote access through the Set Options list.

To set your password:

1. Press the Set Options key.
2. Press **↓** **↑** to scroll to number 12 or press **1****2** to go directly to the item.
3. Press *****.
4. Using the dial pad enter your four digit password.
5. Press **Save**.
6. Press **RLS**.

Note : The 9516CW comes with the password set at 2222. We recommend that you change your password when you are personalizing your telephone.

To listen to your messages remotely:

1. Dial the telephone number of the remote 9516CW.
2. While the greeting is playing, press ***X**. Even if your answering machine is turned off, it will still pick up after 15 rings to allow you to turn it on or access other options.
3. Enter your password.
4. Press **1** for Callers and listen to the prompts.
5. Press **Rls**.

Remote Access

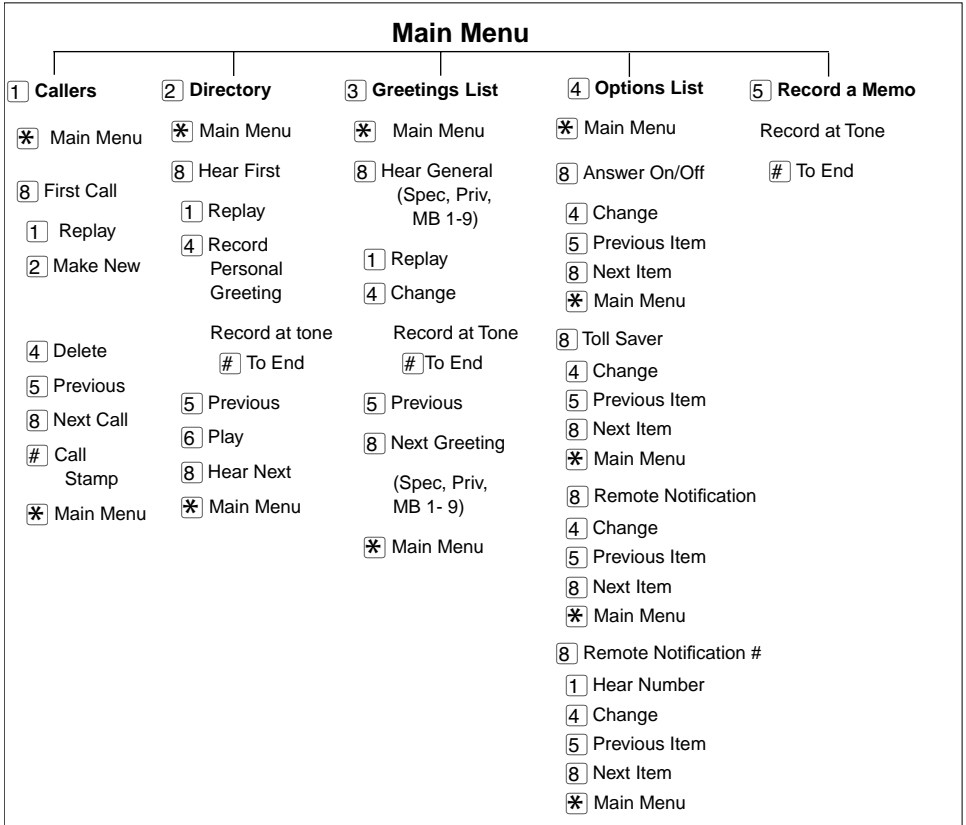

Display messages and lights

The 9516CW has a back-lit three-line display that uses icons and messages for your call information as shown below.

The Callers List screen

A Sample Callers List screen is shown below.

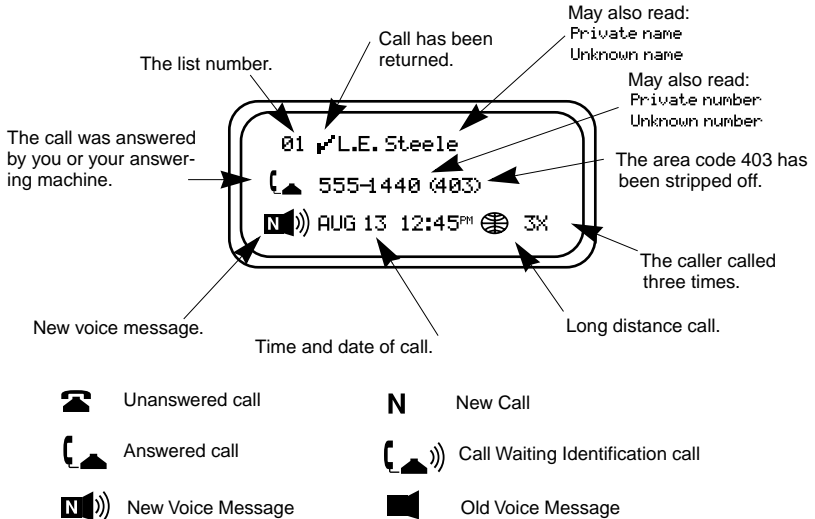

Knowing when you have a Voice Mail message

The 9516CW's set indicator light lets you know that your telephone company Voice Mail system has a message for you. The set indicator light flashes slowly and the display shows **Message Waiting** after your voice mail has received a call. Contact your local telephone company to find out how you can subscribe to Voice Mail services.

Clear Message Waiting







There may be times when **Message Waiting** appears on the display when there are no more voice messages. You can turn the display message off using the Clear Message Waiting feature.

To clear message waiting:

1. Press the Set Options key.
2. Use \downarrow \uparrow to scroll to number six or press $0\ 6$ to go directly to the item.
3. Press \times to clear message waiting.
4. Press RLS .







Note : This only applies when you subscribe to Voice Mail services from your telephone company.

General display messages

Message	What it means
Check line cord	If there is no dial tone, make sure the line cord and handset cord are attached securely.
Data transfer	The transfer of Directory information from one 9516CW to another 9516CW has begun.
Data transfer aborted	The transfer of Directory information has been aborted.
Restricted Number	The number you have entered cannot be dialed because it has been entered into the Dialing Restrictions feature.
Directory empty Use SAVE to add	The Directory remains empty until you add numbers and names to it.
Directory full No changes made	The Directory has a 75 entry limit. If you want to add an item, delete an item you no longer use.
Extension in use	An extension telephone is using the same line that you want to use. Wait until the message disappears before making your call.
Feature ON	The FeatureLight On key has been pressed and the code dialed out. To turn off the feature and the light, press the FeatureLight Off key and lift the handset or press either  OR  .
<Forwarded call	The call is forwarded from another telephone.
Key is locked	The memory key is factory-programmed and cannot be erased or reprogrammed. Program a different memory key.
	The caller is calling from outside your local area. Long distance dialing is required to return the call.
Message Waiting	Your Voice Mail service has received a call for you. To subscribe to voice mail service contact your telephone company.
Private number or Private name	The caller has requested that the telephone company not deliver the number or name.
Redial list is empty	This appears if you press  before making any calls on your telephone or if power has been interrupted.
Ringer is OFF	The ringer volume is turned off. To turn the ringer on; without lifting the handset, press the right side of the volume bar.
Unknown name or Unknown number	The name or number is unavailable from the telephone company.
>...xxxxxxxxxxxxxxxxx ...xxxxxxxxxxxxxxxxx	The telephone number is longer than the display. The display shows ... and 14 or 15 digits of the number depending on whether the phone is on or off hook.
	Indicates an incoming call.
	Indicates that the telephone is off hook.

Message	What it means
	Indicates an incoming Call Waiting call.
XX New Messages	Indicates the number of new messages in your 9516CW answering machine.
XX New Callers	When you are not on the telephone and not in the Callers List, the display shows you how many callers have been added to the list since you last checked it.
Key in use Delete to change	You have tried to save to a memory key that already contains an entry. First delete the existing entry, then try again.

Callers List display messages

Message	What it means
Callers List is empty	Your telephone does not record incoming calls until you subscribe to the Calling Line Identification service. If you do subscribe, you have not received any calls in the list yet or you have deleted all numbers in the Callers List.
Bumped calls=xx	xx is the number of old calls automatically removed to make room for incoming new calls in the Callers List. The limit is 50 calls.
<Forwarded	The call is forwarded from another location.
	The caller has called from outside your local area. Long distance dialing is required to return the call.
No number	You are trying to call someone in your Callers List and the number is unknown or private.
Private number or Private name	The caller has requested that the telephone company not deliver the number or name.
Unknown name or Unknown number	The name or number is unavailable from the telephone company.
N MAR04 3:30PM 2x	N means a new call.
...xxxxxxxxxxxxxxxxxx	... means the number is longer than the display.
01/Unknown Name	✓means you have returned the call from the Callers List.
01 Memo	Means you have a saved memo.
	Indicates an unanswered call in the Callers List
	Indicates an answered call in the Callers List
	Indicates a Call Waiting call in the Callers List
R Smith 123-456-7890 MAR 04 3:30PM 2x	2x means this caller has called twice. The display shows the date and time of the last call from that caller.
	Indicates a new voice message in the Callers List.
	Indicates a played voice message in the Callers List.

Learning about the Lights

The 9516CW's set indicator light also alerts you when another extension is on the line, the telephone rings, a call is on hold or a feature is on. There is a small red light beside

 to show you the status of handsfree and mute.

Set indicator light messages



Feature	Light
Call is on hold	Set indicator light flashes quickly.
Extension in use	Set indicator light is on.
Feature ON	Set indicator light is on.
Message Waiting [†]	Set indicator light flashes slowly.
Visual Ringing	Set indicator light flashes very quickly.
x New Messages	Set indicator light flashes quickly.

[†]You must subscribe to Voice Mail services from your telephone company for this feature to work.

Handsfree indicator light messages

Feature	Light
Call is on Handsfree	Handsfree/Mute indicator light is on.
Microphone is muted	Handsfree/Mute indicator light flashes quickly.

Viewing multiple display and light messages

When you are not using the telephone, there are several messages that can be active at any time, such as **X New Callers**, **Feature ON**, **Ringer is OFF** and **X New messages**. When more than one of these messages is active, the display shows the most recent message and an arrow beside it (e.g., **1 New Caller →**). You can view the other messages by pressing . Each time you press , the display shows the next active message and its associated light.

Special Information about your 9516CW

If a power failure occurs while you are on your call, your call will not be disconnected. Your 9516CW is capable of maintaining your call during a power failure.

If a power failure occurs while you are on a handset call:

- Your call will continue as usual with no interruptions.

If a power failure occurs while you are on a handsfree call:

- Your call is automatically placed on hold.
- Lift the handset to retrieve the call.

Note: The display on your 9516CW will be blank during the power interruption.

When power is restored to the telephone, it will re-initialize just as it did when you originally set up the 9516CW. The telephone display will show:

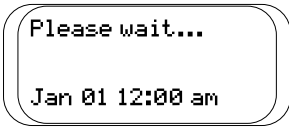

for approximately 15 seconds.

Note: If you did not retrieve your handsfree call before power was restored, the telephone will display will show:

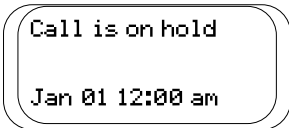

after the "Please wait..." display is cleared.

✱TIPS

- If you subscribe to Calling Line Identification services from your local telephone company, the date and time will be automatically reset for you after receiving your first incoming call. If you do not subscribe to Calling Line Identification services, you must set the date and time manually. See **Setting the date and time** on page 10 in the 9516CW Installation and User Guide for more information.
- All stored Directory items and call information in the Callers List in your 9516CW will be saved during a power failure.

Troubleshooting

The display is in the alternate language.

You can change to the other language by pressing the Set Options key, then pressing **01** and pressing *****.

The cursor does not move when I am saving in the Directory.

The number or name is too long. Numbers can be no longer than 24 digits and names can be no longer than 16 characters.

Callers are not identified on the display.

Let the telephone ring at least twice before answering. If that does not work, you may not have Calling Line Identification[†] service. To subscribe, contact your local telephone company.

The Callers List is empty.

Until you subscribe to Calling Line Identification[†] service, your telephone does not record incoming calls.

The Handsfree / speakerphone is not working.

If the speakerphone is not working, the option for the headset may be enabled. To fix this problem, go to option 22 and turn it off.

I cannot hear a caller or be heard.

Make sure the handset cord is inserted securely into the jack and make sure the receiver volume is high enough.

The caller is hearing the greeting twice before being able to leave a message.

The auto attendant, option 19, has been enabled, which makes the greeting play two times. Disable this option to correct the problem.

The power is out and the display is blank.

9516CW still operates as a regular telephone during a power failure. You can dial using the dial pad and you can receive calls, but the answering machine, other keys or the display will not operate until the power is restored.

The display works but you cannot hear a dial tone.

Your telephone lines may be wired differently from the telephone jack. To have a service person correct the wiring, contact your local telephone company.

Also check to ensure that the Headset mode is disabled.

The telephone wobbles.

Check that the handset cord is placed in the channel between the stand and the telephone. See the illustration on page 4.

I cannot program a memory key.

Some of the memory keys may be factory-programmed. These keys are locked and cannot be erased or reprogrammed.

[†] The actual name for this service may differ in your area. Please consult your telephone company for information.

Call Waiting Identification information is not being displayed.

Make sure that the Call Waiting Identification information option is enabled, and that you have subscribed to a Call Waiting ID[†] service.

I am unable to call back from the Callers List.

The Callers List will record the area code of any call, including local calls. You need to take the area code out when dialing numbers from the Callers List.

How do I record a greeting?

For detailed instructions on recording a greeting, refer to **Greetings** on page 13.

How do I answer Call Waiting?

To answer a Call Waiting call, press . You may have to subscribe to a Call Waiting[†] service to use this feature.

I can view regular Caller ID information, so why can't I see who is calling on Call Waiting?

Ensure that the Call Waiting Identification option (option 26) is on, and that you have subscribed to a Call Waiting ID[†] service from your telephone company. Also note that you will not receive Call Waiting ID when an extension is in use.

How do I connect my fax to work with this phone?

To set up a fax machine to work with the M9516CW, you must first subscribe to a Distinct Ring[†] service through your telephone company. Connect the fax to the M9516CW jack marked **2** . Next, set the fax machine to pick up after at least three rings (consult the fax machine manual for details). Finally, enable the fax switch option (option 20) on the M9516CW. For more details, refer to **Connecting an optional fax machine or modem** on page 4 and **The Fax Switch** on page 49.

How do I set up call announcement?

Call announcement must be turned on in the Option List for either Name & Number, or Name Only. To get names to announce, voice tags must be recorded with an associated directory entry. Refer to **Call Announce (Voice Tag)** on page 22 for more information.

How do I have the M9516CW notify a pager of new messages?

First, set option 17 to on. Under option 18, enter the pager number as the Remote Notify number. For more information, refer to **Remote Notification** on page 54.

How do I listen to old messages?

You must find the associated caller ID entry in the Callers List. Old messages are saved with the caller ID for that call.

Why does my greeting say, “We are unable to take your call – please call back later”?

You have used up the thirty minutes available recording time. Delete old messages and greetings to free up recording time for new messages.

[†] The actual name for this service may differ in your area. Please consult your telephone company for information.

Index

A

- Answering Machine
 - number of rings before answering 12
 - turning off/on 12
- Area codes 46
- Automated Attendant 52

C

- Call Announce (Voice Tag) 22
 - options 23
 - recording a name 22, 23
 - setting the volume 11
- Call Blocking
 - enabling/disabling 51
- Call Display
 - see Calling Line Identification
- Call Waiting Identification 8
 - turning display on/off 10
- Call Waiting tone
 - see Call Waiting Identification
- Callers key 2
- Callers List 33
 - deleting in 35
 - dialing long distance 34
 - display messages 59
 - editing 34
 - finding items 33
 - listening to messages 34
 - making a call 34
 - making a message new again 35
 - saving to memory keys 35
- Calling
 - from a memory key 39
 - from the Callers List 34
 - from the Directory 28
 - from the Redial List 7
- Calling Line Identification 6, 8, 10, 13, 15,
22, 26, 29, 33, 38, 59, 62
- Calls
 - answering 6
 - call screening 18
 - Call Waiting 8
 - calling from the Redial List 7
 - handsfree 7
 - intercepting unwanted 18
 - making 6
 - muting 7
 - putting a call on hold 6

CLID

see Calling Line Identification

- Connecting
 - fax or modem 4
 - handset cord 4
 - line cord 4
 - power adaptor 4

Contrast key 2

- Cords
 - see Connecting

D

- Date and time 10
- Delete key 3
- Deleting
 - area codes 46
 - dialing restrictions 47
 - Directory items 29
 - items in the Callers List 35
 - memory key 40
 - memos 19
 - messages 17, 18
 - page key 44
 - Redial List 7
 - security number 48
 - timer key 43
- Dial key 3
- Dial pad
 - entering names 22
 - selecting the mode 45
- Dialing
 - long distance 34
 - restrictions 47
- Directory
 - deleting items 29
 - editing 28
 - entering names 22
 - finding items 27
 - key 2
 - making a call from 28
 - personalized greeting 26, 38
 - saving numbers and names 20
 - transfer 50
- Display
 - language
 - changing 10
 - messages 58
 - Callers List 59
 - general 58

Index

E

Editing

- area codes 46
- dialing restrictions 47
- mailbox names 30
- memory keys 40
- Security numbers 48
- the Callers List 34
- the Directory 28

F

- Fax Switch 49
- Feature Light keys 42
- Finding items
 - in Options List 3
 - in the Callers List 33
 - in the Directory 27

Flash

- see Link, SuperFlash

G

- General greeting 29
- Greetings
 - Automated Attendant 52
 - choosing to skip 30
 - general 29, 31
 - key 3
 - personalized 26, 38
 - private 15
 - special 14
 - trouble shooting 62

H

- Handsfree 7
- Handsfree/Mute key 3
- Headset
 - using 51
- Hold 6
 - key 2

I

- Installation 4

K

- Key descriptions 2

L

- Language
 - see Display language
- Left Arrow key 2
- Letters
 - entering 22

Lights 60

Link

- Call Waiting Identification 9
- key 3
- SuperFlash 9

Long distance calling 34

M

Mailboxes

- Announce Only 29
- editing 30
- greetings 30
- Normal 29
- Ring Through 29

Memory keys 36

- deleting 40
- editing 40
- labeling 38
- making calls from 39
- predialing from 39
- saving Feature/light to 41
- saving from the display 37
- saving numbers and names 36
- trouble shooting 62

Memos

- deleting 19
- listening to 19
- making new 17
- recording 19

Message Waiting 58, 60

- clear 57

Messages

- audible alert 16
- auto playback 16
- Callers List display 59
- calling party
 - control 18
 - skip 30
- clear Message Waiting 57
- deleting
 - all 18
 - one at a time 17
- listening
 - from the Callers List 34
 - remotely 56
- make new 17
- page 44
- Remote Notification 54
- see also Playback
- Voice Mail 57, 58, 60

Index

Mute 7

O

Options 3

P

Page

key 43, 44

volume control 11

Pager 54

Passwords 55

Pause 14, 54

Play key 3

Playback

auto 16

listen privately 16

options 17

R

Record key 3

Redial

key 3

list 7

Release key 2

Remote Access 55

Remote Notification 54

Right Arrow key 2

Ring tone

setting 11

S

Save key 2

Saving

Feature Off code 41

Feature On code 41

feature/light to memory keys 42

from display

to Directory 25

to memory key 37

from the Callers List 35

numbers/names

to memory keys 36

to the Directory 21

Scroll key 2

Security numbers feature 48

Set Options

key 2

list 3

Setting

Call Announce (Voice Tag) volume

11

date and time 10

Fax Switch 49

number of rings 12

Remote Access password 55

remote notification number 54

ring tone 11

SuperFlash 9

T

Timer Key

adding 43

Toll saver

turning on/off 18

V

Voice Mail 57, 58, 60

see also Message Waiting 57

Voice Tag,

see Call Announce (Voice Tag)

Volume

handset 11

key 3

muting a Handsfree call 7

receiver 11

ringer 11

speaker 11

turning the ringer on/off 11

LIMITED WARRANTY

Aastra Telecom warrants this product against defects and malfunctions during a one (1) year period from the date of original purchase. If there is a defect or malfunction, Aastra Telecom shall, at its option, and as the exclusive remedy, either repair or replace the telephone set at no charge, if returned within the warranty period.

If replacement parts are used in making repairs, these parts may be refurbished, or may contain refurbished materials. If it is necessary to replace the telephone set, it may be replaced with a refurbished telephone of the same design and color. If it should become necessary to repair or replace a defective or malfunctioning telephone set under this warranty, the provisions of this warranty shall apply to the repaired or replaced telephone set until the expiration of ninety (90) days from the date of pick up, or the date of shipment to you, of the repaired or replacement set, or until the end of the original warranty period, whichever is later. Proof of the original purchase date is to be provided with all telephone sets returned for warranty repairs.

EXCLUSIONS

Aastra Telecom does not warrant its telephone sets to be compatible with the equipment of any particular telephone company. This warranty does not extend to damage to products resulting from improper installation or operation, alteration, accident, neglect, abuse, misuse, fire or natural causes such as storms or floods, after the telephone is in your possession.

Aastra Telecom shall not be liable for any incidental or consequential damages, including, but not limited to, loss, damage or expense directly or indirectly arising from the customers use of or inability to use this telephone, either separately or in combination with other equipment. This paragraph, however, shall not apply to consequential damages for injury to the person in the case of telephones used or bought for use primarily for personal, family or household purposes.

This warranty sets forth the entire liability and obligations of Aastra Telecom with respect to breach of warranty, and the warranties set forth or limited herein are the sole warranties and are in lieu of all other warranties, expressed or implied, including warranties or fitness for particular purpose and merchantability.

WARRANTY REPAIR SERVICES

Should the set fail during the warranty period;

In North America, please call 1-800-574-1611 for further information.

Outside North America, contact your sales representative for return instructions.

You will be responsible for shipping charges, if any. When you return this telephone for warranty service, you must present proof of purchase.

AFTER WARRANTY SERVICE

Aastra Telecom offers ongoing repair and support for this product. This service provides repair or replacement of your Aastra Telecom product, at Aastra Telecom's option, for a fixed charge. You are responsible for all shipping charges. For further information and shipping instructions;

In North America, contact our service information number: 1-800-574-1611.

Outside North America, contact your sales representative.

Note: Repairs to this product may be made only by the manufacturer and its authorized agents, or by others who are legally authorized. This restriction applies during and after the warranty period. Unauthorized repair will void the warranty.

GENERAL INQUIRIES

If you have read the guide and you still have questions, call 1-800-574-1611 in Canada and the USA. In other areas, contact your telephone company.